

STORAGE COMPAT®

The smart side of space



www.storagecompat.com



On the road to success, order is your most powerful ally. It is the compass that guides you to your greatest goals and dreams.

This catalog can be downloaded directly from our website www.storagecompat.com

**STORAGE
COMPAT®**

Where are we?



STORAGE COMPAT LLC

Blue Lagoon, Miami Nth. Florida
sales@storagecompat.com

ABOUT US

Storage Compat is a multinational company dedicated to manufacturing and marketing products that help optimize production times, storage organization and distribution throughout the Americas efficiently and effectively. Our products are designed in line with European developments, in order to improve production and service



processes in the Americas, and be consistent with the principal XXI century world economies.

Our commitment with innovation and the study of new materials allow us to offer more than 15,000 production items to be used in

a wide range of industrial, food, health, commercial, residential and school sectors.

Our integral offer combines different types of plastic and metal, from conductive materials to be used by the electronic industry to sanitary options for both hospital and food sectors. Our products are robust and durable, with a long lifetime and a 5 year

warranty. Their uniform design worldwide provides the best solutions.

In our production plant, we transform more than 2,200 tons of raw material a year, with a targeted growth of more than 30% a year for the next 10 years. We offer internationally approved quality products to the five continents. With a 90,000 m

industrial plant, we guarantee a solid development in our region, offering a new perspective in our segment.

Customers from all sectors recognize that efficiency and life quality are achieved with order and growth. Our customer base of 50,000 companies all over the world is constantly growing, 17,500 of which are between Alaska and Bahia de Ushuaia in Argentina.

We have prepared ourselves to expand with a wide distribution network in the Americas, offering an innovative and standard

proposal that fulfills with professionalism the needs of our customers. Our design, the result of many years of experience, guarantees that customers decide on Storage Compat products for their production plants, hospitals, food sectors, laboratories, public and private institutions, aerospace, automotive and many other industries. Customers find that our products help them with the organization, efficiency and reliability they need for their operations.

"Storage Compat. Integral Equipment. Order and efficiency."

CEO & Founder in the Americas:

Alejandro Lavorgna

Sales Directors:

Francisco Boni Plaza & Julieta Lavorgna

Production Director:

Nicolás Lavorgna



WE DEVISE

Being aware that more suitable solutions are necessary, as well as the fact that an idea is waiting for you to be realized, is our guiding philosophy when developing new businesses and viable ideas. A simple phrase or an unthinkable situation may give rise to some incentives that encourage us to create efficient and simple solutions needed or requested by our customers.

WE PROJECT

Well trained designers and modern tools give birth to the initial idea.



WE IMPLEMENT

With industrial-scale production efficiency, we generate forecasting and adaptation capacity, two qualities that are always applied by Storage Compat because they are in our DNA. After many years of work experience, we have become, and continue to be, the leaders of our industry, implementing new solutions, technologies and processes. The result is a durable, aesthetically pleasing, ergonomic, and user-friendly solution. We pay special attention to the product quality, which has been approved following the most recent international standards.

INDEX

01 PLASTICS

- ATHENA Series Containers
- Conductive ESD System
- ZEUS Series
- PRACTIBOX Series
- MULTIBOX Series
- PALLET
- KLT Series
- NETTUNO Series

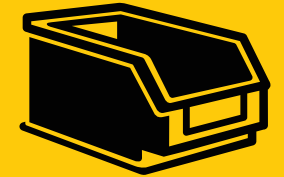

02 TRANSPORT CARTS

- Transport carts
- Carts with bins and containers



03 WORKBENCHES

- Workbenches
- STEEL Workbenches



04 METAL CABINETS

- Bins storage cabinets
- Tool cabinets
- Janitorial storage cabinets / Wardrobes
- Safety storage cabinets
- Computer cabinets



05 DRAWER UNITS

- Metal drawer units with or without wheels



06 SHELVING SYSTEM

- MODULAR shelving system
- Boltless fitting shelving system
- Ladder cart with automatic brake system



"In the search for excellency, every detail is a pillar of order, creating high quality products that transcend expectations."

ATHENA

ATHENA Series storage containers have been developed and studied to support heavy duties and assist production lines. They may be manual, automated or with a flow racking system. Specially designed for the automotive sector, today they are a world reference due to their modularity on standard pallets and their truck transportation capacity. With thick edges and grooved walls, these heavy-duty containers may support an average of 110.23lb. each at rest and 881.85b. when stacked. These values are maintained even during transportation, especially in the South America region where roads are frequently in bad conditions. The ATHENA Series has passed several shock tests, becoming the most resistant standardized series of containers in the Mercosur region.

Their handles, base and walls may be solid or open (perforated), with 6 different configurations in each dimension available.

Color: Black
 Good resistance to grease and oils. Robust and resistant to high and low temperatures, depending on their conditions of use, with a maximum thermal



STORAGE COMPAT.

ATHENA SERIES - GENERAL OPTIONS



CONTAINER VERSIONS

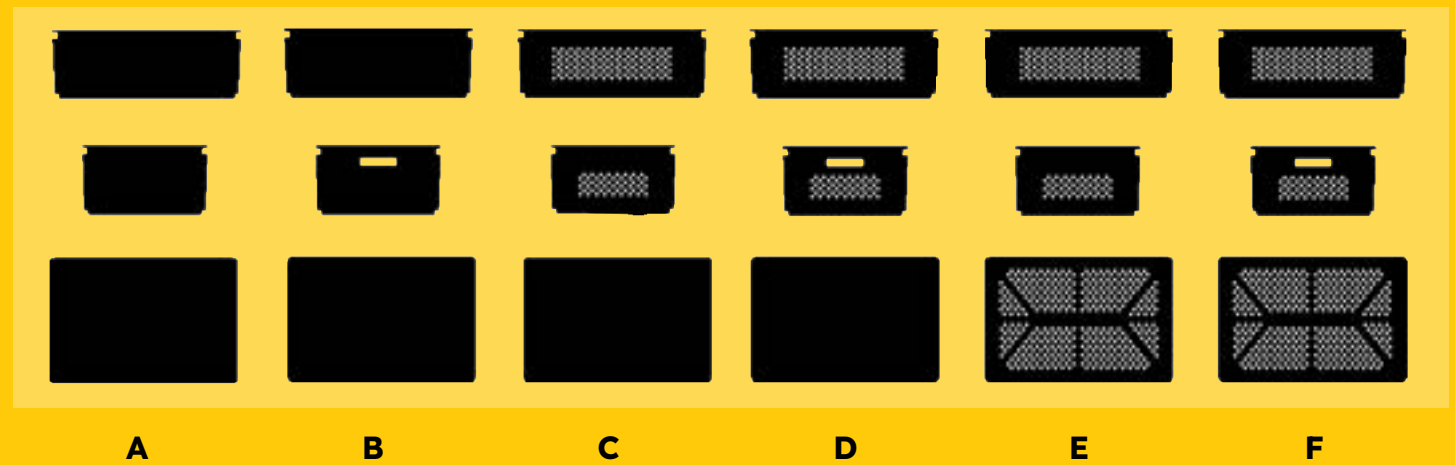



Handles: Closed
Walls: Solid
Base: Closed
Capacity: 1.6 Gal..

Code 3215/A
Outer Dim.: 11.8 x 7.9 x 5.9 H In
Inner Dim.: 10.6 x 7.7 x 5.7 H In

Containers 15.7"x11.8"



Handles: Closed
Walls: Solid
Base: Closed
Capacity: 2.64 Gal..

Code 4312/A
Outer Dim.: 15.7 x 11.8 x 4.7 H In
Inner Dim.: 14.0 x 10.0 x 3.9 H In



Handles: Closed
Walls: Perforated
Base: Perforated
Capacity: 2.64 Gal..

Code 4312/E
Outer Dim.: 15.7 x 11.8 x 4.7 H In
Inner Dim.: 14.0 x 10.0 x 3.9 H In



Handles: Closed
Walls: Solid
Base: Closed
Capacity: 3.96 Gal..

Code 4317/A
Outer Dim.: 15.7 x 11.8 x 6.7 H In
Inner Dim.: 14.0 x 10.0 x 5.9 H In



Handles: Closed
Walls: Solid
Base: Closed
Capacity: 5.28 Gal..

Code 4322/A
Dim. Ext: 15.7 x 11.8 x 8.7 H In
Dim. Int: 14 x 10 x 7.9 H In



Handles: Open
Walls: Solid
Base: Closed
Capacity: 5.28 Gal..

Code 4322/B
Dim. Ext: 15.7 x 11.8 x 8.7 H In
Dim. Int: 14 x 10 x 7.9 H In



Handles: Closed
Walls: Solid
Base: Closed
Capacity: 7.9 Gal..

Code 4332/A
Outer Dim.: 12.8 x 11.8 x 13.6 H In
Inner Dim.: 12 x 10 x 12 H In



Handles: Closed
Walls: Solid
Base: Closed
Capacity: 7.9 Gal..

Code 4332/B
Outer Dim.: 12.8 x 11.8 x 13.6 H In
Inner Dim.: 12 x 10 x 12 H In



Containers 23.6"x15.7"



Handles: Closed
Walls: Solid
Base: Closed
Capacity: 528 Gal.

Code 6412/A
Outer Dim.: 23.6 x 15.7 x 4.7 H In.
Inner Dim.: 21.9 x 14 x 3.9 H In.



Handles: Closed
Walls: Perforated
Base: Closed
Capacity: 528 Gal.

Code 6412/C
Outer Dim.: 23.6 x 15.7 x 4.7 H In.
Inner Dim.: 21.9 x 14 x 3.9 H In.



Handles: Closed
Walls: Perforated
Base: Perforated
Capacity: 528 Gal.

Code 6412/E
Outer Dim.: 23.6 x 15.7 x 4.7 H In.
Inner Dim.: 21.9 x 14 x 3.9 H In.



Handles: Closed
Walls: Solid
Base: Closed
Capacity: 7.92 Gal.

Code 6417/A
Outer Dim.: 23.6 x 15.7 x 6.7 H In.
Inner Dim.: 21.9 x 14 x 5.9 H In.



Handles: Closed
Walls: Solid
Base: Closed
Capacity: 10.6 Gal..

Code 6422/A
Outer Dim.: 23.6 x 15.7 x 8.7 H In.
Inner Dim.: 21.9 x 14 x 7.9 H In.



Handles: Open
Walls: Solid
Base: Closed
Capacity: 10.6 Gal..

Code 6422/B
Outer Dim.: 23.6 x 15.7 x 8.7 H In.
Inner Dim.: 21.9 x 14 x 7.9 H In.



Handles: Open
Capacity: 10.6 Gal..
Walls: Perforated
Base: Perforated

Code 6422/F
Outer Dim.: 23.6 x 15.7 x 8.7 H In.
Inner Dim.: 21.9 x 14 x 7.9 H In.



Handles: Open
Walls: Solid
Base: Closed
Capacity: 60 L

Code 6432/B
Outer Dim.: 23.6 x 15.7 x 12.8 H In.
Inner Dim.: 21.9 x 14 x 12 H In.



Handles: Closed
Walls: Solid
Base: Closed
Capacity: 60 L

Code 6432/A
Outer Dim.: 23.6 x 15.7 x 12.8 H In.
Inner Dim.: 21.9 x 14 x 12 H In.



Handles: Closed
Walls: Perforated
Base: Closed
Capacity: 60 L

Code 6432/D
Outer Dim.: 23.6 x 15.7 x 12.8 H In.
Inner Dim.: 21.9 x 14 x 12 H In.





Handles: Open
Walls: Perforated
Base: Closed
Capacity: 23.7 Gal.



Handles: Open
Walls: Solid
Base: Closed
Capacity: 23.7 Gal.



Handles: Open
Walls: 3 solid and 1 half open
Base: Closed
Capacity: 23.7 Gal.

Code	6443/D	Code	6443/B	Code	6443/S
Outer Dim.:	23.6 x 15.7 x 16.9 H In.	Outer Dim.:	23.6 x 15.7 x 16.9 H In.	Outer Dim.:	23.6 x 15.7 x 16.9 H In.
Inner Dim.:	21.9 x 14.0 x 16.1 H In.	Inner Dim.:	21.9 x 14.0 x 16.1 H In.	Inner Dim.:	21.9 x 14.0 x 16.1 H In.

HINGED LIDS WITH HANDLES



LIDS FOR CONTAINERS 15.7 x 11.8"
CODE: TP4300 With hinges
CODE: TP4301 Without hinges



LIDS FOR CONTAINERS 23.6 x 15.7"
CODE: TP6400 With hinges
CODE: TP6401 Without hinges



Space for strapping.



Clips may be added to secure the lids to the containers.



A hinge system that is easily installed in containers.



Ergonomic handle.



PAIRS OF CLIPS FOR THE LID
Code: FPZ06810013
Pair of clips suitable for sliding hinged lids of the ATHENA series containers, with the following dimensions: 4.72"/6.69"/8.66"/12.6"/16.93"
Weight: 0.05 g (x 2 units)

Different Types of Container Handles



Open Handle



Closed Handle

	15.7 x 11.8" 23.6 x 15.7"	11.8 x 7.87" 15.7 x 11.8" 23.6 x 15.7"	15.7 x 11.8" 23.6 x 15.7"	15.7 x 11.8" 23.6 x 15.7"	15.7 x 11.8" 23.6 x 15.7"	15.7 x 11.8" 23.6 x 15.7"
H	4.72"	5.91"	6.69"	8.66"	12.80"	16.93"
Type A						
Type B						
Type C						
Type D						
Type E						
Type F						

	15.7 x 11.8" 23.6 x 15.7"	11.8 x 7.87" 15.7 x 11.8" 23.6 x 15.7"	15.7 x 11.8" 23.6 x 15.7"	15.7 x 11.8" 23.6 x 15.7"	15.7 x 11.8" 23.6 x 15.7"	15.7 x 11.8" 23.6 x 15.7"
H	4.72"	5.91"	6.69"	8.66"	12.80"	16.93"
Type A						
Type B						
Type C						
Type D						
Type E						
Type F						

Different Types of Container Walls



Perforated Wall



Solid Wall

	15.7 x 11.8" 23.6 x 15.7"	11.8 x 7.87" 15.7 x 11.8" 23.6 x 15.7"	15.7 x 11.8" 23.6 x 15.7"	15.7 x 11.8" 23.6 x 15.7"	15.7 x 11.8" 23.6 x 15.7"	15.7 x 11.8" 23.6 x 15.7"
H	4.72"	5.91"	6.69"	8.66"	12.80"	16.93"
Type A						
Type B						
Type C						
Type D						
Type E						
Type F						

	15.7 x 11.8" 23.6 x 15.7"	11.8 x 7.87" 15.7 x 11.8" 23.6 x 15.7"	15.7 x 11.8" 23.6 x 15.7"	15.7 x 11.8" 23.6 x 15.7"	15.7 x 11.8" 23.6 x 15.7"	15.7 x 11.8" 23.6 x 15.7"
H	4.72"	5.91"	6.69"	8.66"	12.80"	16.93"
Type A						
Type B						
Type C						
Type D						
Type E						
Type F						

Different Types of Container Bases



Closed Base



Perforated Base

	15.7 x 11.8" 23.6 x 15.7"	11.8 x 7.87" 15.7 x 11.8" 23.6 x 15.7"	15.7 x 11.8" 23.6 x 15.7"	15.7 x 11.8" 23.6 x 15.7"	15.7 x 11.8" 23.6 x 15.7"	15.7 x 11.8" 23.6 x 15.7"
H	4.72"	5.91"	6.69"	8.66"	12.80"	16.93"
Type A						
Type B						
Type C						
Type D						
Type E						
Type F						

	15.7 x 11.8" 23.6 x 15.7"	11.8 x 7.87" 15.7 x 11.8" 23.6 x 15.7"	15.7 x 11.8" 23.6 x 15.7"	15.7 x 11.8" 23.6 x 15.7"	15.7 x 11.8" 23.6 x 15.7"	15.7 x 11.8" 23.6 x 15.7"
H	4.72"	5.91"	6.69"	8.66"	12.80"	16.93"
Type A						
Type B						
Type C						
Type D						
Type E						
Type F						

Other types of ATHENA container bases



Perforated base for 4322P / 4332P / 6422P ATHENA CONTAINERS



Reinforced base for RB/RA ATHENA CONTAINERS

ACCESSORIES



Code	6404P000	Code	FCP 201102 99	Code	FCP 201101 99
	KAN BAN Label Holder		Cart with handle to carry ATHENA 15.75x11.8" and 23.6x15.7" containers With 4 Ø 3.94" swivel casters Dim.: 24.2 x 16.34 x 6.69/34.25 H Inch. Load capacity: 330.7 Lb.		Cart to carry ATHENA 15.75x11.8" and 23.6x15.7" containers With 4 Ø 3.94" swivel casters Dim.: 24.21" x 16.34" x 6.69" H Load capacity: 330.7 Lb.

CONDUCTIVE PLASTIC CONTAINERS

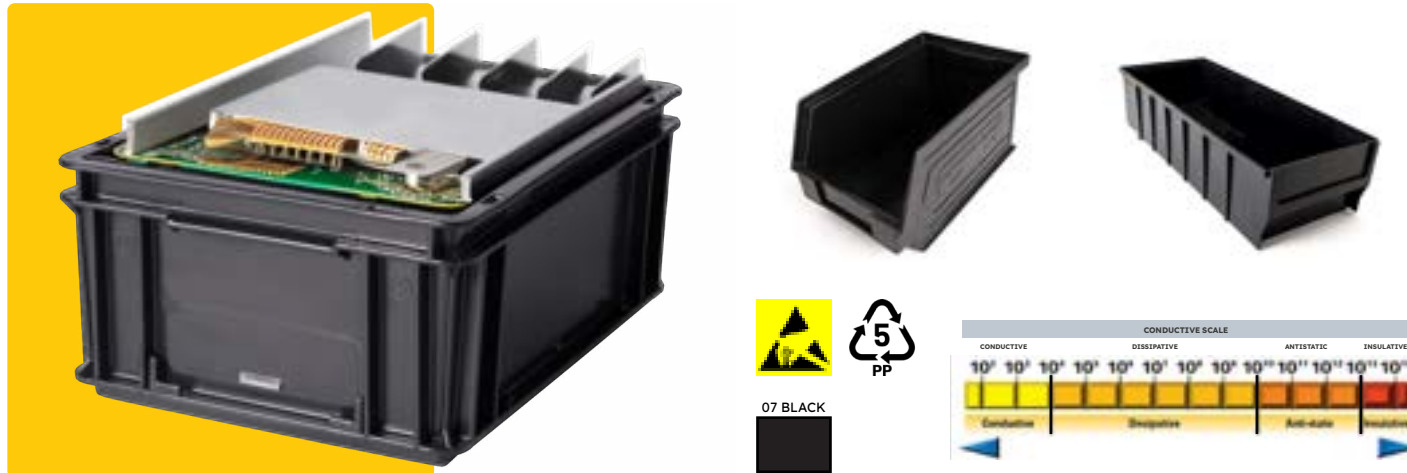

Plastic conductive bins and containers are ideal for handling electronic components. Electrical components are always exposed to natural environment electrical charges, such as magnetic and electric fields, air humidity and radioactive radiations, which are a negative management for their storage and transportation. This may damage parts and, sometimes, destroy the electronic components. As conductive plastic containers are made of materials that can "conduct and discharge" parasitic or static electrical current, they can safely store and carry electronic components. Electronic components are protected against undesirable electrical charges.

Ordinary plastic containers are an ideal mean of transportation and packaging for the mechanical industry, but they are not for the electronics sector. In this case, it is necessary to avoid the use of ordinary containers or packaging methods with standard non-conductive plastic containers, as these are optimal insulators and, therefore, they accumulate electrostatic charges that seriously damage electronic components. In order to continue using plastic containers, which are considered the best means by modern logistics, we have developed this particular system of conduction allowing our containers to discharge electrical currents generated by the environment and the constant movements. The special conductive Storage Compat 408L plastic allows us to develop plastic containers for the electronic industry, offering a suitable protection of components against electrostatic charges.

HOT STAMPING



With hot stamping (a procedure based on high temperature), we can print on the plastic surface a previously prepared logotype or image, as requested. With this procedure, the printed image remains permanent during the product lifespan. The image is engraved on a mold that can be stamped on almost any ATHENA series container, including on lids.

In order to ensure order and protection of delicate material that should not touch other products during transportation or storage, Storage Compat has designed and developed a partition system for plastic containers. They are made of plastic. They have with different sizes, and slots with 0.787" in. spacing that allow a rational and varied partition of containers' inner space, as needed.



SERIE inches 1.77 H

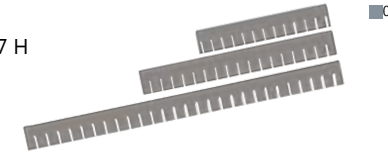

Item Code	Dim. inches	Slot spacing inch	For containers Series
FHN 1320 00 01	10.04" x 1.77"	0.79"	15.7"x11.8"
FHN 1420 00 01	13.98" x 1.77"	0.79"	15.7"x11.8" / 23.6"x15.7"
FHN 1620 00 01	21.85" x 1.77"	0.79"	23.6"x15.7"



SERIE Inches 2.76" H

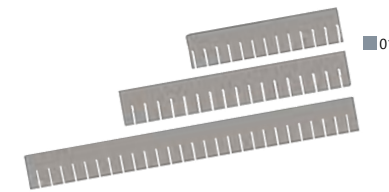

Item Code	Dim. inches	Slot spacing inch	For containers Series
FHN 1340 00 01	10.04" x 2.76"	0.79"	15.7"x11.8"
FHN 1440 00 01	13.98" x 2.76"	0.79"	15.7"x11.8" / 23.6"x15.7"
FHN 1640 00 01	21.85" x 2.76"	0.79"	23.6"x15.7"

SERIE inches 3.54" H

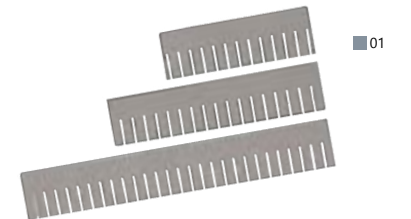

Item Code	Dim. inches	Slot spacing inch	For containers Series
FHN 1350 00 01	10.04" x 3.54"	0.79"	15.7"x11.8"
FHN 1450 00 01	13.98" x 3.54"	0.79"	15.7"x11.8" / 23.6"x15.7"
FHN 1650 00 01	21.85" x 3.54"	0.79"	23.6"x15.7"

SERIE inches 4.72" H

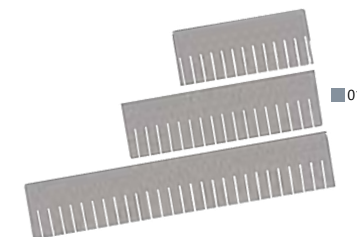

Item Code	Dim. inches	Slot spacing inch	For containers Series
FHN 1360 00 01	10.04" x 4.72"	0.79"	15.7"x11.8"
FHN 1460 00 01	13.98" x 4.72"	0.79"	15.7"x11.8" / 23.6"x15.7"
FHN 1660 00 01	21.85" x 4.72"	0.79"	23.6"x15.7"

SERIE inches 7.09" H

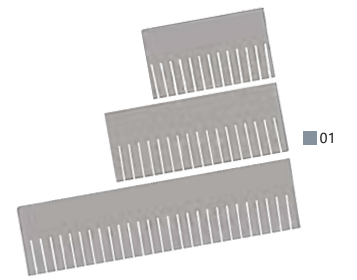

Item Code	Dim. inches	Slot spacing inch	For containers Series
FHN 1370 00 01	10.04" x 7.09"	0.79"	15.7"x11.8"
FHN 1470 00 01	13.98" x 7.09"	0.79"	15.7"x11.8" / 23.6"x15.7"
FHN 1670 00 01	21.85" x 7.09"	0.79"	23.6"x15.7"

INTERMEDIATE LEVEL

USE OF INTERMEDIATE LEVEL

This partition system divides the container in different levels, so you can have more than one product level in the same container.

Item Code	Dim. Inch.
FHN 5140 00 01	21.85" x 13.98"



ZEUS

Polypropylene **ZEUS** bins are the ideal solution for different types of storage problems, whether in warehouses, assembly lines or workshops. They offer the possibility of maintaining products tidy and within reach, saving money in man hours and, therefore, in competitiveness by lowering stock and operative costs.

They can be stacked with stability, and you can access the stored material even when it is piled. They can be handled safely and effectively with their ergonomic handles, protecting our workers' health.



STORAGE COMPAT.



1PLZ
6.30" x 5.51" x 3.74" H In.
Cap. 0.264 Gal.



2PLZ
9.06" x 7.87" x 5.51" H In.
Cap. 1.003 Gal.



3A2PLZ
13.78" x 11.81" x 5.71" H In.
Cap. 2.481 Gal.



3PLZ
13.78" x 11.81" x 7.87" H In.
Cap. 3.302 Gal.



4PLZ
19.69" x 17.72" x 11.81" H In.
Cap. 7.396 Gal.



4A5PLZ
19.69" x 17.72" x 11.81" H In.
Cap. 11.163 Gal.

STORAGE COMPAT.



GAMA DE COLORES 00 01 02 03 04 05 06



Item Code	1 PLZ
Outer Dim. inches	6.30" x 5.51" x 3.74" H
Inner Dim, inches	0.52" x 0.35" x 0.26" H
Cap. Gallons	0.264
Load Capacity Lbs	4.40

Item Code	2 PLZ
Outer Dim. inches	9.06" x 7.87" x 5.51" H
Inner Dim, inches	7.48" x 4.88" x 4.37" H
Cap. Gallons	1.004
Load Capacity Lbs	11.02

Item Code	3A2 PLZ
Outer Dim. inches	13.78" x 11.81" x 5.71" H
Inner Dim, inches	11.22" x 7.17" x 5.12" H
Cap. Gallons	2.48
Load Capacity Lbs	33

Item Code	3 PLZ
Outer Dim. inches	13.78" x 11.81" x 7.87" H
Inner Dim, inches	10.94" x 7.24" x 7.09" H
Cap. Gallons	3.30
Load Capacity Lbs	44.09

Item Code	4A5 PLZ
Outer Dim. inches	19.69" x 17.72" x 11.8" H
Inner Dim, inches	17." x 11.02" x 11.18" H
Cap. Gallons	11.1
Load Capacity Lbs	77.16

Item Code	4 PLZ
Outer Dim. inches	19.69" x 17.72" x 11.8" H
Inner Dim, inches	17.13" x 11.02" x 7.17" H
Cap. Gallons	7.39
Load Capacity Lbs	77.16



Longitudinal Dividers

For Bin 3 PLZ FND01400099
For Bin 4 PLZ FND01800099



Dividers

For Bin 3 PLZ FND11090099
For Bin 4 PLZ FND11100099



STACKABLE



ERGONOMIC HANDLES



SMOOTH BASE



Organize your spaces



Item Code	Description
ZIKETI00408	28-label sheet for 1PLZ containers
ZIKETI00508	21-label sheet for 2PLZ - 3A2PLZ containers
ZIKETI00608	15-label sheet for 3PLZ-4PLZ-4A5PLZ containers

ZEUS Plastic Bins

They are designed to perfectly integrate with other Storage Compat products, enhancing their versatility



Improve work conditions and maximize order



Adaptable to cabinets.



Adaptable to transportation carts.



Adaptable to bin storage cabinets.



Adaptable to mobile shelving unit



Adaptable to modular shelving unit

Simplify your life with our **ZEUS** plastic bins

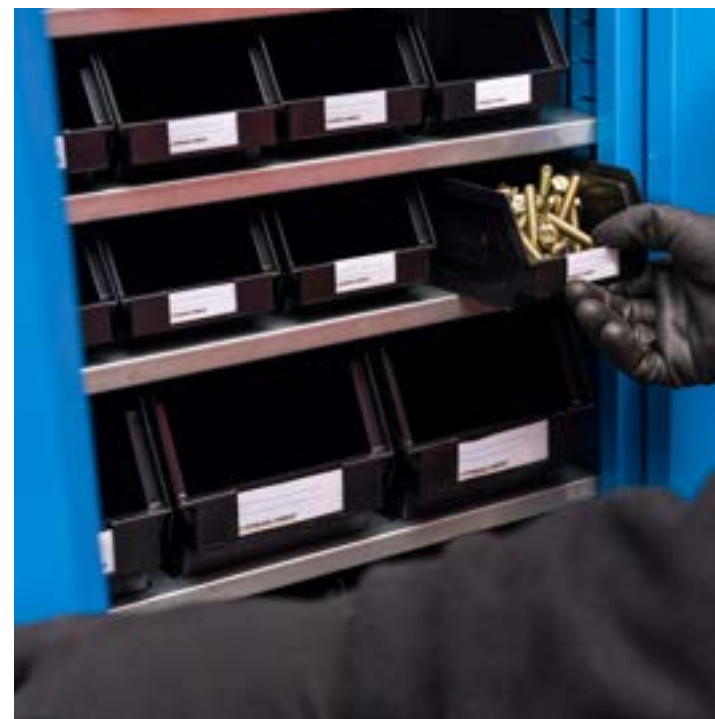

MULTIBOX

Hygienic and stackable plastic bins. Ideal for shelving units. The best system to ensure a good organization of different types of parts, as you can add transversal transparent dividers to maintain order. Bins may be delivered with labels to identify items easily and promptly. They also have a security stop that prevents the bin from accidentally falling off the shelving. They are acid - and bleach-resistant.



STORAGE COMPAT.

MULTIBOX SERIES - GENERAL OPTIONS



SERIES COLOR

Black: RAL 9005

Blue: RAL 5012





Item Code	RK4016 04
Outer Dim. inches	15.75" x 6.30" x 3.94" H
Inner Dim. inches	15.16" x 5.71" x 3.54" H
Maximum number of dividers:	6 units
Divider Code	RK160

Item Code	RK5016 04
Outer Dim. inches	19.69" x 6.30" x 3.94" H
Inner Dim. inches	19.09" x 5.71" x 3.54" H
Maximum number of dividers:	8 units
Divider Code	RK160

Item Code	RK6016 04
Outer Dim. inches	23.62" x 6.30" x 3.94" H
Inner Dim. inches	23.07" x 5.71" x 3.50" H
Maximum number of dividers:	10 units
Divider Code	RK160

Optional Accessories

Bin Labels



Item Code	Container Model - Item	Label Dim.	Number of labels per sheet
FPK 9580 00 00	RK 4016	4.76x1.73 in.	8
	RK 5016		
	RK 6016		

Divider Labels



Item Code	Mod. Contenedor Art.	Dim. Etiqueta	Cant. etiquetas por hoja
FPK 9560 00 00	RK 160	4.76x0.94 in.	16

Bin Dividers



Item Code	Dim. inches.
RK160	5.71x3.54 in.
For bins Item.	RK 4016
	RK 5016
	RK 6016

Transparent adjustable inner dividers with frontal and inner label holders in each divider. Module metal stop. (From 6 to 10 transparent inner dividers)

Security Back Stop



Security Back Stop for **RK4016 / RK5016 / RK6016** bins

F PK 9420 00 99

MULTIBOX BIN MODULES



Item Code	Series Color	Dim. Inches.	For Bins	Max. Number of Bins
FPK 9040 02 01	GREY RAL 7000	19.69x15.75x21.46 in.	MULTIBOX RK4016	12
FPK 9050 02 01		19.69x19.69x21.46 in.	MULTIBOX RK5016	
FPK 9060 02 01		19.69x23.62x21.46 in.	MULTIBOX RK6016	

Module BASE



Item Code	Dim. inches	For Item
F PK 9145 00 01	19.09x14.76x3.54 in.	F PK 9040 00 01
F PK 9155 00 01	19.09x18.70x3.54 in.	F PK 9050 00 01
F PK 9165 00 01	19.09x22.64x3.54 in.	F PK 9060 00 01

Modular stackable FPK shelving units for MULTIBOX plastic bins. The simplest and more practicable solution to arrange your work or storage space. MULTIBOX bins can be perfectly stacked in the modules for space saving. They are stackable in up to 4 levels, with multiple bin size configurations. Bins easily slide in and out of the shelves because they have a smooth surface. Thanks to the module design, a stop system may be added to the MULTIBOX bins to prevent them from falling off the shelving unit.



Positioning slots.



Positioning flaps.



The most efficient system to ensure an optimal organization: **MULTIBOX PLASTIC BINS**



NETTUNO

Plastic collapsible storage containers are used in the logistic, industrial and commercial industry.

They are light-weighted but heavyduty. They are stackable. They can be folded flat or opened easily and safely. They are made of virgin polypropylene to resist breaks and most oils, acids and bleaches.

Their hinged lids can be secured with a security seal. Your company logotype may be printed with serigraphy (screen printing) or hot stamping because the outer walls are smooth. There is a space available for the label and the bar code.

They are very useful in the logistic sector to reduce transportation costs. For every 6 trucks loaded with goods, only 1 truck is necessary to return the empty folded flat containers, saving money and ensuring a rapid return on investment.



STORAGE CIMPAT.



NETTUNO SERIES - GENERAL OPTIONS

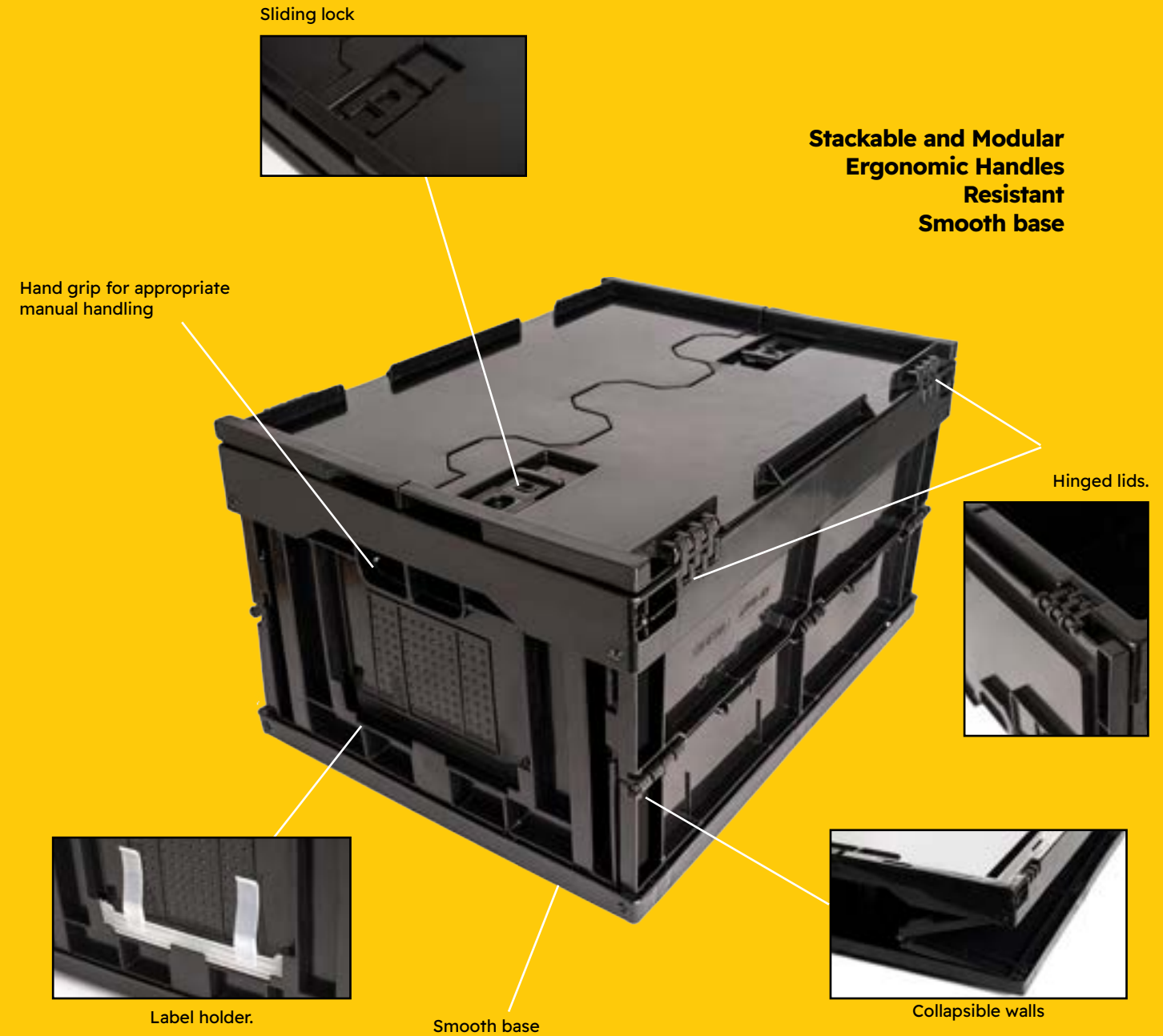

6 to 1 Ratio.





**The
collapsible
solution
suitable for
every sector**



Item Code	4323-B
LID Item TP4303	
Series Color	Black
Cap. Gallons	5.81
Container weight Lbs.	2.24 / 2.89
Outer Dim. inches	15.7"x11.8"x 9.06" H
Useful Inner Dim. in.	14.02"x10.04"x7.87 H

Item Code	6423-B
LID Item TP6403	
Series Color	Black
Cap. Gallons	11.88
Container weight Lbs.	4.02 / 5.59
Outer Dim. inches	23.6"x15.7"x 9.06" H
Useful Inner Dim. in.	21.69"x13.98"x8.03" H

Item Code	6433-B
LID Item TP6403	
Series Color	Black
Cap. Gallons	17.17
Container weight Lbs.	5.39 / 6.59
Outer Dim. inches	23.6"x15.7"x 13" H
Useful Inner Dim. in.	21.69"x13.98"x11.97"

From their ergonomic handles to their sealable lids, **NETTUNO** combines functionality and exceptional adaptability



Stackable



Plastic Label Holder

6405P000 (8.27" in) for 23.6"x15.7" model
6406P000 (5.91" in) for 15.7"x11.8" model



Container Lid

TP4303 15.7"x11.8" inches.
TP6403 23.6"x15.7" inches.

Collapsible, practical and powerful, **NETTUNO** exceeds the container category. This series becomes your ally in pursuit of a perfect organization.



**Try now and save 6 to 1
in transportation!**

NETTUNO collapsible containers, where elegance blends with efficiency. Order, organization and commitment with a more sustainable future.

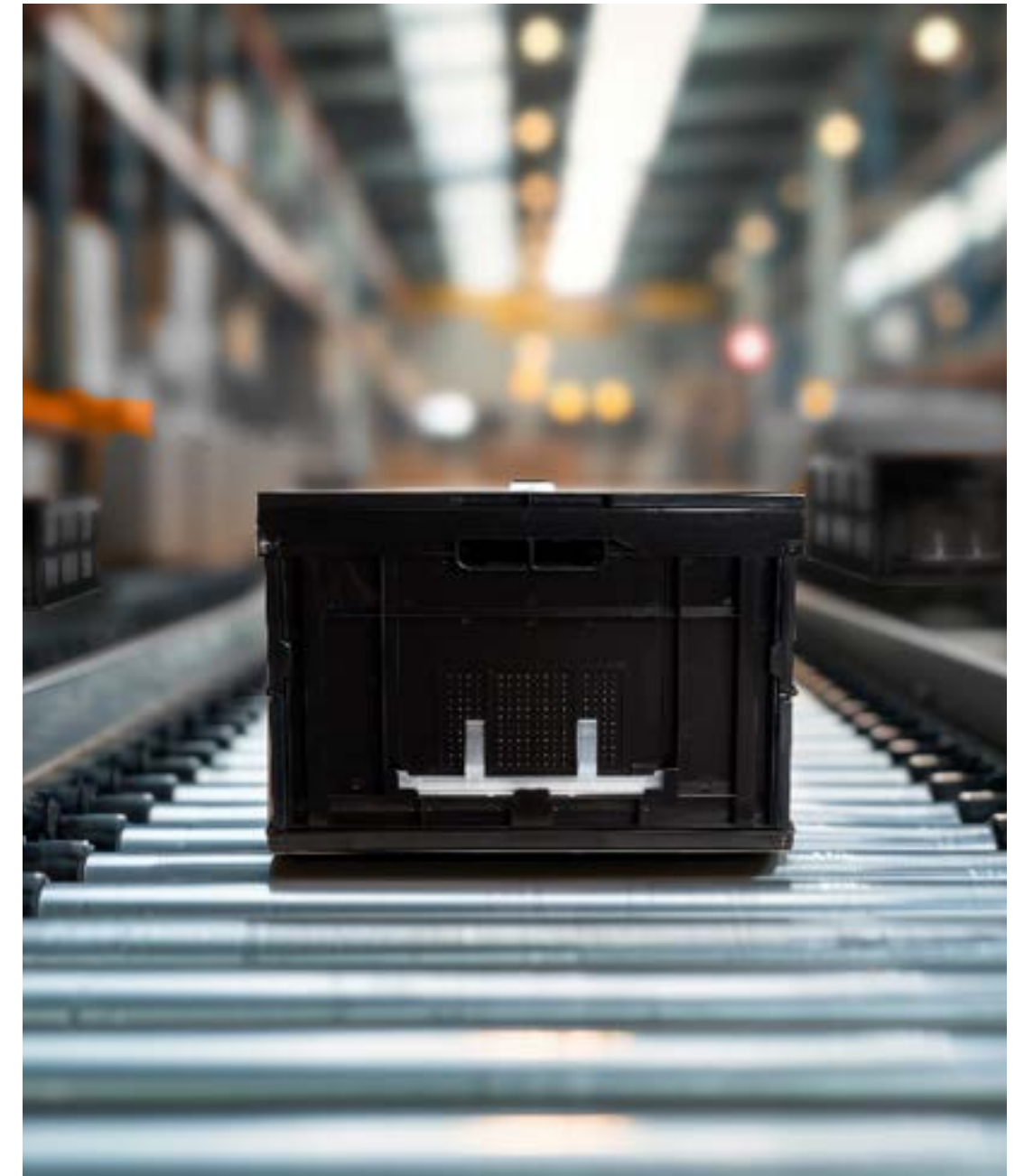

PRACTIBOX

PRACTIBOX is an organizational and storage system combining high quality plastic and metal raw materials, designed to be durable and resistant to impacts.

It is made of high impact polystyrene, with transparent bins and containers to visualize the contents easily.

It is ideal for storing and organizing a great variety of items of different industries.

With its stackable design, you can create an attractive retail display; they also help maintain your warehouse well organized.

PRACTIBOX containers can be opened and are completely removable, facilitating their access, filling, cleaning or movement to a work station.

Containers have a big space with a slot to insert labels and/or bar codes.

The PRACTIBOX system may be used in a great variety of shelving units, carts and modular cabinets.

We can help you find the perfect model for you!



STORAGE COMPAT.



PRACTIBOX SERIES - GENERAL OPTIONS



Label slot.



Stackable.



6 different models.

Order.

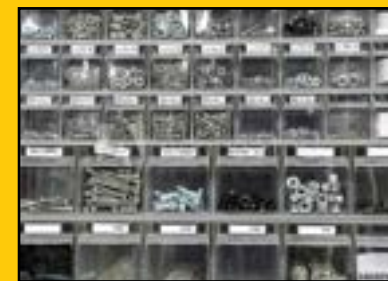

Tilt-opening bin.

The ideal solution to efficiently organize a variety of items



Item Code FPG10710101
9-bin model
Dim. 23.62 x 2.72 x 3.03 H inches



Item Code FPG15710101
6-bin model
Dim. 23.62x3.86x4.41 H inches



Item Code FPG20710101
5-bin model
Dim. 23.62x5.55x6.46 H inches



Item Code FPG25710101
4-bin model
Dim. 23.62x5.79x8.11 H inches



Item Code FPG30710101
3-bin model
Dim. 23.62x8.23x9.45 H inches



Item Code FPG35710101
2-bin model
Dim. 23.62x12.24x13.90 H inches



FPG 0320 01 01
Dim. 24.02x7.20x19.69 H inches
PRACTIBOX Accessories:
1 Item FPG 1571 01 01
1 Item FPG 2071 01 01
1 Item FPG 2571 01 01

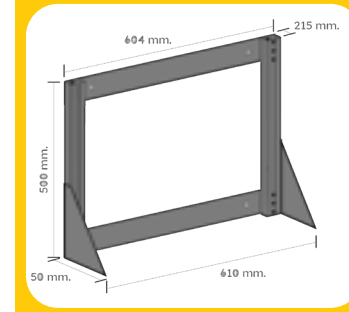

FPG 0320 00 01
Dim. 24.02x5.91x19.69 H inches
WORKBENCH frame



FPG 0410 00 01
Dim. 23.62x1.10x11.81 H inches
METAL SHEET FRAME



Item Code FPG 0410 01 01
Dim. 23.62x3.07x12.13 H inches
Complete with:
4 Item FPG 1071 01 01



Item Code FPG 0410 02 01
Dim. 23.62x4.21x11.81 H inches
Complete with:
1 Item FPG10710101
4 Item FPG15710101



Item Code FPG 0410 03 01
Dim. 23.62x5.91x12.91 H inches
Complete with: 2 Item FPG20710101



FPG 0420 00 01
Dim. 23.62x1.10x19.69 H inches
METAL SHEET FRAME



Item Code FPG 0420 01 01
Dim. 23.62x3.07x19.69 H inches
Complete with: 6 Item FPG10710101



Item Code FPG 0420 02 01
Dim. 23.62x4.21x19.69 H inches
Complete with: 2 Item FPG10710101
3 Item FPG15710101



Item Code FPG 0420 03 01
Dim. 600x183x500 H inches
Complete with: 1 Item FPG15710101
1 Item FPG20710101
1 Item FPG25710101



SHELVING UNIT WITH BASE

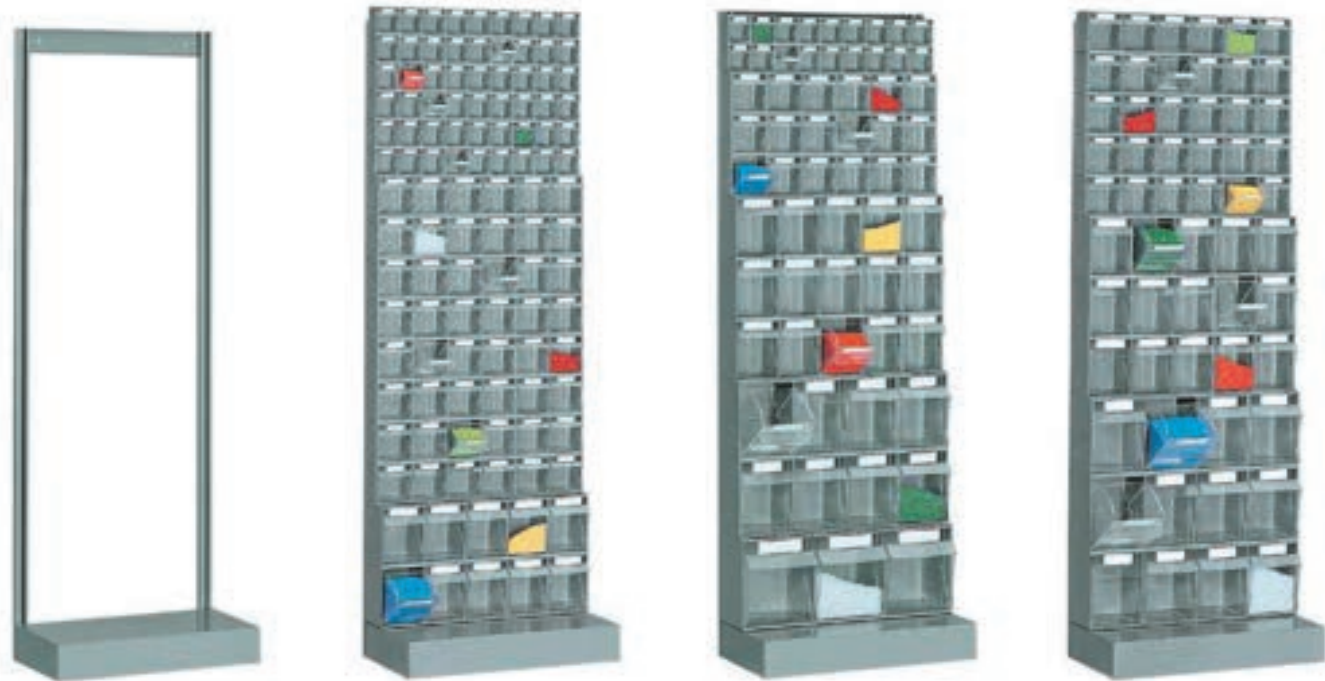

Item Code FPG 0650 00 01	Item Code FPG 0650 02 01	Item Code FPG 0650 03 01	Item Code FPG 0650 04 01
Dim. 23.62x12.80x68.90 H inches	Dim. 23.62x12.80x70.31 H inches	Dim. 23.62x12.80x68.90 inches	Dim. 23.62x12.80x69.69 H inches
Useful Height: 64.96 inches	Complete with: 6 Item FPG10710101 8 Item FPG15710101 2 Item FPG20710101	Completo de: 2 Item FPG10710101 3 Item FPG15710101 3 Item FPG20710101 2 Item FPG25710101 1 Item FPG30710101	Complete with: 5 Item FPG15710101 3 Item FPG20710101 3 Item FPG25710101
METAL BASE FRAME 01 - Structure	01 -Structure / 96 bins	01 -Structure / 96 bins	01 -Structure / 96 bins

SHELVING UNIT WITH BASE

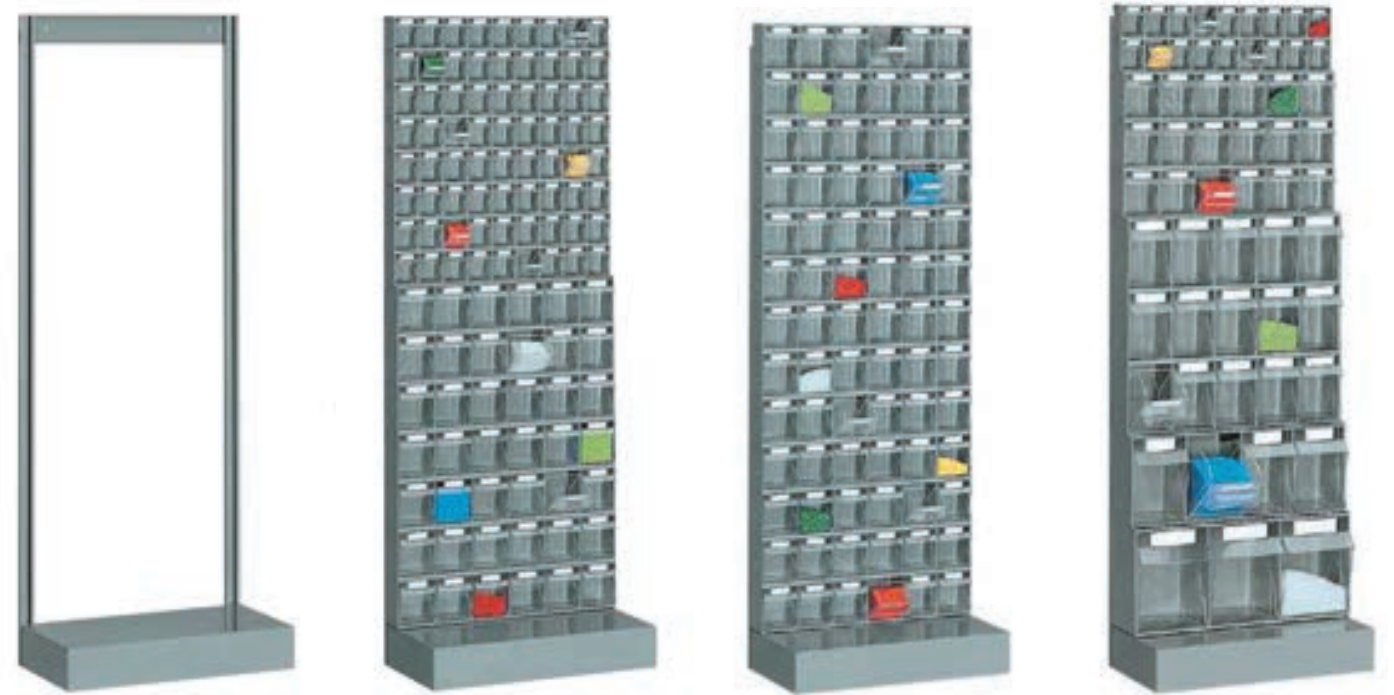

Item Code FPG 0640 00 01	Item Code FPG 0640 01 01	Item Code FPG 0640 02 01	Item Code FPG 0640 03 01
Dim. 23.62x12.80x59.06 inches	Dim. 23.62x12.80x59.06	Dim. 23.62x12.80x61.26 H inches	Dim. 23.62x12.80x60.16 H inches
Useful Height: 55.12 inches	Complete with: 8 Item FPG10710101 7 Item FPG15710101	Complete with: 13 Item FPG15710101	Complete with : 2 Item FPG10710101 3 Item FPG15710101 3 Item FPG20710101 1 Item FPG25710101 1 Item FPG30710101
Metal base frame 01 - Structure	01 -Structure / 96 bins	01 - Structure/ 96 bins	01 - Structure / 96 bins

Easy fitting onto the base



Removable bins



Item Code	For Container
FPG 0910 00 99	FPG 1071 01 01
FPG 0915 00 99	FPG 1571 01 01
FPG 0920 00 99	FPG 2071 01 01
FPG 0925 00 99	FPG 2571 01 01
FPG 0930 00 99	FPG 3071 01 01
FPG 0935 00 99	FPG 3571 01 01



IDEAL FOR MOVING LARGES PIECES



Ergonomic handle

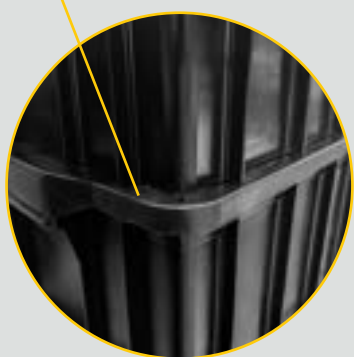

Stackable



Reinforced outer base



Smooth base



Item Code	9651/A
Outer Dim. inches	39.37x15.75x9.13 H
Capacity in Gallons	17.17 gal.
Standard Color	BLACK

ASK FOR OTHER COLORS



Item Code	9540/A
Outer Dim. inches	39.37x15.75x4.72 H
Capacity in Gallons	8.72 gal.
Standard Color	Black

ASK FOR OTHER COLORS



BASE WITH SUPPORT STANDS



SMOOTH BASE



Item Code	RL-KLT 4329
Outer Dim. inches	15.7"x11.8"x280 h
Capacity in Gallons	5.81 gal.
Smooth base	

Item Code	R-KLT 4329
Outer Dim. inches	15.7"x11.8"x280 h
Capacity in Gallons	5.81 gal.
Base with support stands	



Item Code	RL-KLT 6429
Outer Dim. inches	23.6"x15.7"x280 h
Capacity in Gallons	12.68 gal.
Smooth base	

Item Code	R-KLT 6429
Outer Dim. inches	23.6"x15.7"x280 h
Capacity in Gallons	12.68 gal.
Base with support stands	

* Optional plastic label holder for all models



Item Code	F PU 4050 00 07
PLASTIC PALLET	
DIMENSIONS	
STATIC CHARGE CAPACITY 11023 lb	
DYNAMIC CHARGE CAPACITY 3307 lb	
COLOR: BLACK	

Item Code	F PU 4550 00 07
PLASTIC LID	
DIMENSIONS 47.24x39.37 inches	
COLOR Black	

IMPORTANT: NOT SUITABLE FOR CHEMICAL FLUIDS



Item Code	F PT 1040 00
Dimensions in inches	39.37x25.20x25.79 H
Capacity in Gallons	73.97 gal.
Load capacity in lb.	330.7 lb
SERIES COLOR: Black	

Item Code	FPT 7040 00
Lid for Item FPT 1040 00	

Metal Carts

Standardized industrial carts with a robust folded and welded steel structure, made of the type of galvanized steel sheet used in the automotive industry, becoming more resistant and with a longer lifespan.

Storage Compact carts are small mobile warehouses with plastic containers and shelves.

Before being painted, they are subject to a washing and phosphating treatment. Later, an electrostatic powder coating is applied. Application of the polyurethane paint makes them suitable for outdoor use. They have been certified by the most important paint manufacturers, ensuring their quality and durability.





Item Code FCR 0021 01

Load Capacity 330.7 lb
 Dimensions: 21.85x17.52x33.27 H inches
 Cart with 2 swivel casters WITHOUT brakes and 2 rigid casters Ø3.94" standard rubber

Item Code FCR 0021 03

Load Capacity 330.7 lb
 Dimensions: 21.85x17.52x33.27 H inches
 Cart with 2 swivel casters WITHOUT brakes and 2 rigid casters Ø3.94" standard rubber



Item Code FCR 0091 00

Load Capacity 330.7 lb
 Dimensions: 36.22x20.08x31.89 H inches
 Modular cart with 2 swivel casters with brakes and 2 rigid casters Ø3.94" standard rubber



Item Code FCR 0091 01

Load Capacity 330.7 lb
 Dimensions: 36.22x20.08x31.89 H inches
 Cart with 2 swivel casters WITH brakes and 2 rigid casters Ø3.94" standard rubber



Item Code FCE B105 03

Load Capacity 551.2 lb
 Dimensions: 44.69x27.56x36.02 H inches
 Cart with 2 swivel casters with brakes and 2 rigid casters Ø4.92" standard rubber



Item Code FCE P105 04

Load Capacity 1102.31 lb
 Dimensions: 44.69x27.56x39.37 H inches
 Cart with 2 swivel casters WITH brakes and 2 fixed wheels Ø7.87" standard rubber



Item Code FCE P105 12

Load Capacity 1102.31 lb
 Dimensions: 47.24x27.56x39.37 H inches
 Cart with 2 swivel casters WITH brakes and 2 fixed wheels Ø7.87" standard rubber



Item Code FCR 0715 00

Load Capacity 220.5 lb
 Additional shelf for FCR0091 cart
 Dimensions: 31.89x20.08x2.13 H inches



Item Code FCE P105 06

Load Capacity 1102.31 lb
 Dimensions: 44.69x27.56x39.37 H inches
 Cart with 2 swivel casters WITH brakes and 2 fixed wheels Ø7.87" standard rubber



Item Code FCF H005 03

Load Capacity 551.2 lb
 Dimensions: 37.20x20.67x41.14 H inches
 Cart with 2 swivel casters WITH brakes and 2 fixed wheels Ø5.91" standard rubber



Item Code FCF H005 08

Load Capacity 551.2 lb
 Dimensions: 37.20x20.67x41.14 H inches
 Cart with 2 swivel casters WITH brakes and 2 fixed wheels Ø5.91" standard rubber



Item Code FCE P105 20

Load Capacity 1102 lb

Dimensions: 43.11x27.56x39.37 H inches

Cart with 2 swivel casters WITH brakes and 2 fixed wheels Ø7.87" standard rubber



Built to last. Our standardized carts have been manufactured with a solid structure that protects the materials during transportation.



Full cart with 12 containers Mod. 6417A

Item Code FCH P206 14

Load capacity 1102.31 lb

Dimensions: 56.10x24.61x62.60 H inches

Cart with 2 swivel casters with brakes and 2 fixed wheels Ø7.87" standard rubber



Item Code FCH P205 05

Number of Shelves 3

Dimensions: 56.10x24.61x62.60 H inches

Carro con 2 ruedas giratorias con freno y 2 ruedas fijas de Ø7.87" goma estándar



Item Code FCH 0510 00

Load Capacity 220.46 lb

Additional shelf for 50x23.62 inches carts

Dimensions: 50x23.62 inches



Shelf End Support FCHP

Dimensions: 50 x 2.36 H inches



Item Code FAG 9310 00

Stainless steel handle with elbows made of recycled polypropylene plastic

Length: 22.05 inches



Swivel caster with brake



Rigid caster made of standard rubber



CARTS AND SHELVING UNITS FOR BINS AND CONTAINERS

Shelving units for plastic bins and containers are a real mobile warehouse, offering maximum optimization of space available. Made of highly-resistant steel profiles, they guarantee exceptional durability. Shelves made of galvanized metal sheets used in the automotive industry offer higher resistance and longer lifetime. They can support up to 55.12lb. (fixed) and 110.23b. (inclined), protecting the stored materials. Its detachable structure allows an efficient transportation and storage, as well as configuration of shelves and plastic containers following your needs. As their structure is made of galvanized steel, we guarantee resistance and durability necessary for optimal performance in any work environment.





Item Code
FLB B073 52 52
Dimensions: 28.54x24.13x56.30 H inches



Item Code
FLB B073 53 52
Dimensions: 28.54x24.13x56.30 H inches



Item Code
FLB B073 55 52
Dimensions: 28.54x24.13x56.30 H inches



Item Code FLB B101 52 52
Dimensions in inches 40.28x24.13x56.30 H
Full cart with:
1 cart Item FLB B101 02 52 18
18 ZEUS containers Mod. 2PLZ
8 ZEUS containers Mod. 3A2PLZ
6 ZEUS containers Mod. 4PLZ
2 swivel casters with brake Ø4.92 inches
2 rigid casters Ø4.92 standard rubber
Load capacity 661.4 lb (330.69 lb each side)



Item Code FLB B102 52 52
Dimensions in inches 40.28x24.13x56.30 H
Full cart with:
1 cart Item FLB B102 02 52
180 ZEUS containers Mod. 1PLZ
2 swivel casters with brake Ø 4.92 inches
2 rigid casters Ø 4.92 inches standard rubber
Load capacity 661.4 lb (330.69 lb each side)



BACK



Item Code FLB B102 59 52
Dimensions in inches 40.28x24.13x56.30 H
Full cart with:
1 Perforated panel Dim. 995x304
18 ATHENA containers Mod. 3215A
Set of RHINO hooks for 66 tools
2 swivel casters with brake Ø 4.92 inches
2 rigid casters Ø 4.92 inches standard rubber
Load capacity 661.4 lb (330.69 lb each side)



BACK



Item Code	FLB B102 53 52
Dimensions in inches	40.28x24.13x56.30 H
Full cart with:	
	90 bins ZEUS Mod. 1PLZ
	48 bins ZEUS Mod. 2PLZ
	2 swivel casters with brake Ø 4.92 inches
	2 rigid casters Ø 4.92 inches standard rubber
	Load capacity 661.4 lb (330.69 lb each side)



Item Code	FLB B103 53 52
Dimensions in inches	40.28x24.13x56.30 H
Full cart with:	
	1 cart Item FLB B103 03 52
	5 ATHENA containers Mod. 4317A
	2 ATHENA containers Mod. 6417A
	2 ATHENA containers Mod. 6422A
	2 swivel casters with brake Ø 4.92 inches
	2 rigid casters Ø 4.92 inches standard rubber
	Load capacity 661.4 lb (330.69 lb each side)



Item Code	FLB B102 62 52
Dimensions in inches	40.28x24.13x56.30 H
Full cart with:	
	1 cart Item FLB B102 12 52
	9 Containers Mod. 4317A 2
	Containers Mod. 6417A
	2 swivel casters with brake Ø 4.92 inches
	2 rigid casters Ø 4.92 inches standard rubber
	Load capacity 661.4 lb (330.69 lb each side)



Item Code	FLC C173 51 52
Dimensions in inches	42 x 21.34 x 71.54 H
Full cart with:	
	1 shelving unit Item FLC C173 01 52
	9 ATHENA containers Mod. 4317A
	3 ATHENA containers Mod. 6417A
	Load capacity : 330.69 lb



Item Code	FLC C173 53 52
Dimensions in inches	42 x 21.34 x 71.54 H
Full cart with:	
	1 shelving unit Item FLC C173 03 52
	45 ZEUS bins Mod. 1PLZ
	30 ZEUS bins Mod. 2PLZ
	8 ZEUS bins Mod. 3A2PLZ
	Load capacity 330.69 lb



Item Code	FLC A173 51 52
Dimensions in inches	42 x 36.42 x 71.54 H
Full cart with:	
	1 double-sided shelving unit Item FLC A173 01 52
	18 ATHENA containers Mod. 4317A
	6 ATHENA containers Mod. 6417A
	Load capacity 661.4 lb (330.69 lb each side)



Item Code	FLB B102 55 52
Dimensions en inches.	40.28 x 24.13 x 56.30 H
Full cart with:	
	1 shelving unit Item FLBB1020552
	24 ZEUS bins Mod. 2PLZ
	2 Cabinets with shutter FBL 7012 60
	2 sets with 52 RHINO plastic hooks
	Load capacity 661.4 lb (330.69 lb each side)



FIXED Tray 38.35" long

Item Code	FBL 7846 00 99
-----------	----------------

Dimensions in inches	38.35 x 6.69 x 2.40 H
Load capacity : 55.12 lb	
For 9 ZEUS bins Mod. 1PLZ	



FIXED Tray 38.35" long

Item Code	FBL 7847 00 99
-----------	----------------

Dimensions in inches	38.35 x 9.06 x 2.40 H
Load capacity : 55.12 lb	
For 6 ZEUS bins Mod. 2PLZ	



FIXED Tray 38.35" long

Item Code	FBL 7848 00 99
-----------	----------------

Dimensions in inches	38.35 x 12.40 x 2.40 H
Load capacity : 55.12 lb	
For 4 ZEUS bins Mod. 3A2PLZ / 3PLZ	



Item Code	FBL 7012 08
Dimensions	37.48 x 8.27 x 31.89 H inches
Load Capacity	110.23 lb



Top side support



Lower side support

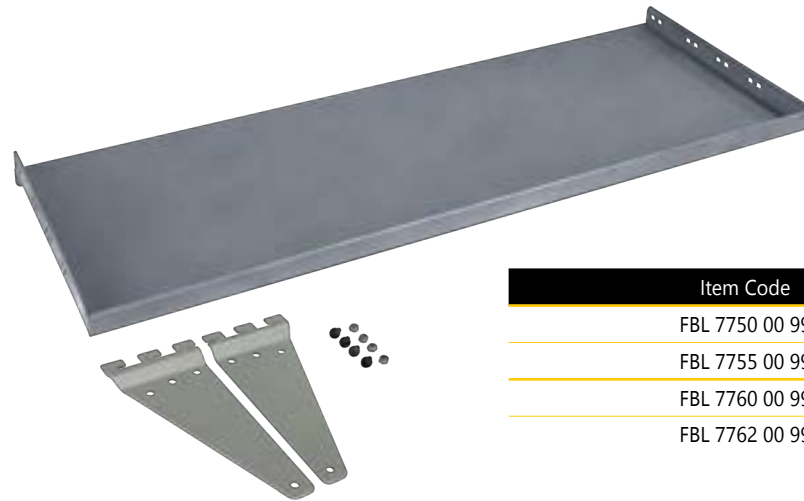

Item Code	Dimensions
FBL 7750 00 99	Depth 8.66 inches (Width = 38.78 inches)
FBL 7755 00 99	Depth 12.60 inches (Width = 38.78 inches)
FBL 7760 00 99	Depth 16.54 inches (Width = 38.78 inches)
FBL 7762 00 99	Depth 24.41 inches (Width = 38.78 inches)

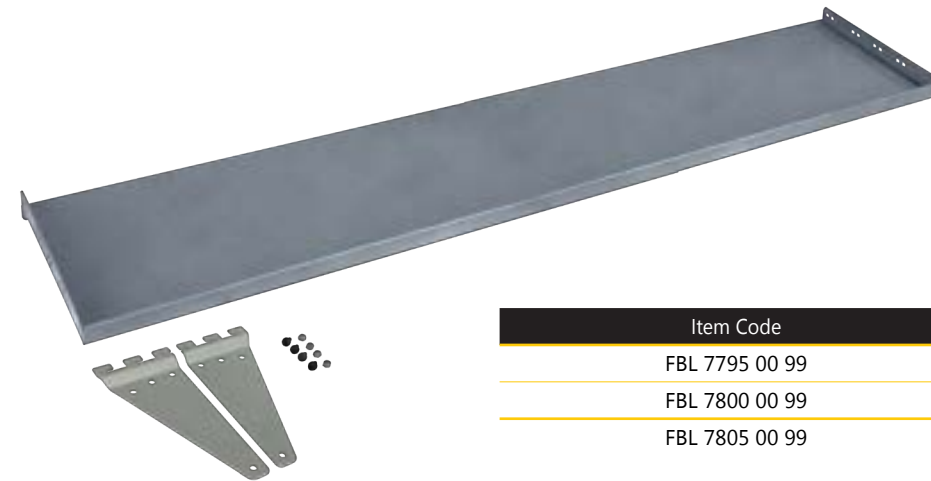

Item Code	Dimensions
FBL 7795 00 99	Depth 8.66 inches (Width = 57.87 inches)
FBL 7800 00 99	Depth 12.60 inches (Width = 57.87 inches)
FBL 7805 00 99	Depth 16.54 inches (Width = 57.87 inches)

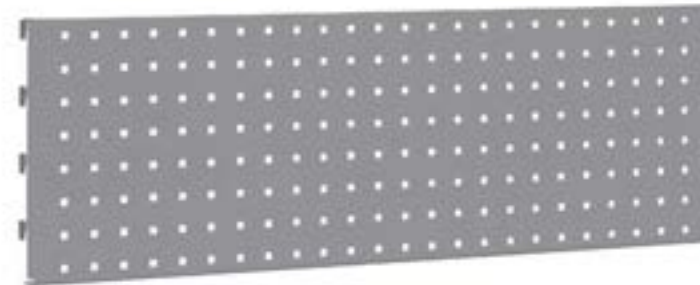

Item Code	FBL 7620 00 08
Dimensions	38.31 inches

Item Code	FBL 7635 00 08
Dimensions	57.40 inches



Item Code	FLD 0001 05 56
Dimensions in inches	61.10x28.43x71.54 H
It consists of:	
1 Grey melamine work surface 57.87x27.56x0.98 H inches	
1 57.87" x 12.60" tray with 55.12 lb capacity	
3 perforated panels 57.87 x 11.97 inches	
1 electrical cable tray	
1 footrest with anti-slip rubber	
It doesn't include: Electric installation / Lamp	



Item Code	FLD 0001 03 56
Dimensions in inches	42x28.43x87.40 H inches
It consists of:	
1 Grey melamine work surface 38.78x27.56x0.98 H inches	
1 38.19" x 9.84" tray with a capacity of 55.12 lb	
2 perforated panels 38.19x11.97 inches	
1 footrest with anti-slip rubber	
It doesn't include: Electrical installation or tools	



Item Code	FLD 0001 02 56
Dimensions in inches	80.79x59.06x87.40 H
It consists of:	
2 Grey melamine work surface 77.56x27.56x0.98 H inches	
2 38.35x8.07 inches tray with 55.12 lb capacity	
1 38.35x5.91 inches trays with 55.12 lb capacity	
2 38.35x8.66 inches tray with 55.12 lb capacity	
2 38.35x12.60 inches trays with 55.12 lb capacity	
4 38.35x23.62 inches tray with 55.12 lb capacity	
4 perforated panels 38.35x11.97 inches	
2 footrests with anti-slip rubber	
2 top light fixtures and supports	
It includes plastic bins and containers	
It doesn't include: Electrical installation/tools	



Item Code	FLD K175 01 56
Dim.	61.10 x 32.28 x 71.54 H inches



Item Code	FLD D125 01 56
Dim.	61.10 x 32.28 x 50.59 H inches



Item Code	FLD V173 01 56
Dim.	79.72 x 32.28 x 71.54 H inches



Item Code	FLD R123 01 56
Dim.	79.72 x 32.28 x 50.59 H inches

PERFORATED PANEL

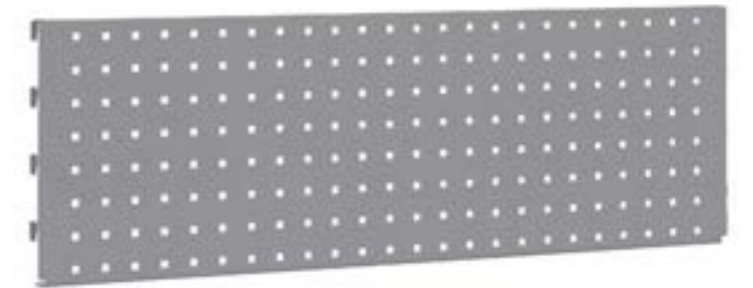

Item Code	FBL 7620 00 08
Dimensions	38.31 inches

Item Code	FBL 7635 00 08
Dimensions	57.40 inches

TILTED TRAY
37.60 INCHES LONG



TILTED TRAY
56.69 INCHES LONG



Item Code	Dimensions
FBL 7795 00 99	Depth 8.66 inches (Width = 57.87 inches)
FBL 7800 00 99	Depth 12.60 inches (Width = 57.87 inches)
FBL 7805 00 99	Depth 16.54 inches (Width = 57.87 inches)

CPU Holder

Item Code	FBL 7620 00 08
-----------	----------------



WORKBENCHES



WORKBENCHES have been developed and manufactured to meet the different market demands. They may be easily transformed due to their versatility and their capacity to adapt to any type of need. There is a great variety of accessories, such as hooks, trays, tool panels, electrical cable tray, that maximize their versatility. They have steel legs with holes on the top to secure the work surface, and on the base plates to be fixed to the ground.

An important element in workbenches is the DRAWER UNIT made with different sizes and offering different solutions, depending on the type of drawer and its inner divisions

STORAGE COMPAT.



WORKBENCHES

WORKBENCHES 13-80

SERIES COLOR



LENGTH= 51.18 in / DEPTH= 31.50 in / HEIGHT= 33.07"/33.46"

Item Code **FBI A32801**

Type of work surface	Metal
Surface thickness	1.57 inches
Load Capacity lb.	2645.55 lb

Steel WORKBENCH thickness from 0.06" to 0.13" Reinforced. After a washing and phosphating treatment, an electrostatic powder coating (suitable for outdoor use) is applied. Certified by the most important paint manufacturers. They may be disassembled for efficient and comfortable transportation. Measures studied for proper ergonomics.

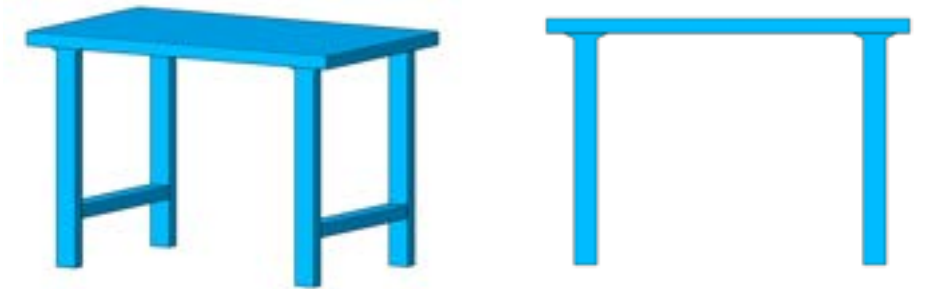

Item Code **FBI A32810**

Type of work surface	Metal
Surface thickness	1.57 inches
Load Capacity lb.	2645.55 lb

Steel WORKBENCH thickness from 0.06" to 0.13" Reinforced. After a washing and phosphating treatment, an electrostatic powder coating (suitable for outdoor use) is applied. Certified by the most important paint manufacturers. They may be disassembled for efficient and comfortable transportation. Measures studied for proper ergonomics.



Item Code **FBI A32813**

Type of work surface	Metal
Surface thickness	1.57 inches
Load Capacity lb.	3306.93 lb

Steel WORKBENCH thickness from 0.06" to 0.13" Reinforced. After a washing and phosphating treatment, an electrostatic powder coating (suitable for outdoor use) is applied. Certified by the most important paint manufacturers. They may be disassembled for efficient and comfortable transportation. Measures studied for proper ergonomics.



Item Code **FBI A528S1**

Dimensions en inches	51.18 x 31.5 x 33.46/83.46 H
Type of work surface	Metal
Thickness in inches	1.57 inches
Load Capacity lb.	2645.55 lb



Item Code **FBI A328S2**

Dimensions in inches.	51.18 x 31.5 x 69.96 H
Type of work surface	Metal
Thickness in inches	1.57 inches
Load Capacity lb.	2645.55 lb



WORKBENCH 15-80

LENGTH= 59.06 in / DEPTH= 31.50 in / HEIGHT= 33.07/33.46 in

SERIES COLOR

Item Code **FBIA34201**

Type of work surface	Metal
Surface thickness	1.57 inches
Capacity in Lb.	2204.62 lb

Steel WORKBENCH thickness from 0.06" to 0.13" Reinforced. After a washing and phosphating treatment, an electrostatic powder coating (suitable for outdoor use) is applied. Certified by the most important paint manufacturers. They may be disassembled for efficient and comfortable transportation. Measures studied for proper ergonomics.

Item Code **FBIA34210**

Type of work surface	Metal
Surface thickness	1.57 inches
Capacity in Lb.	2204.62 lb

Steel WORKBENCH thickness from 0.06" to 0.13" Reinforced. After a washing and phosphating treatment, an electrostatic powder coating (suitable for outdoor use) is applied. Certified by the most important paint manufacturers. They may be disassembled for efficient and comfortable transportation. Measures studied for proper ergonomics.

Item Code **FBIA34216**

Type of work surface	Metálico
Surface thickness	1.57 inches
Capacity in Lb.	2204.62 lb

Steel WORKBENCH thickness from 0.06" to 0.13" Reinforced. After a washing and phosphating treatment, an electrostatic powder coating (suitable for outdoor use) is applied. Certified by the most important paint manufacturers. They may be disassembled for efficient and comfortable transportation. Measures studied for proper ergonomics.

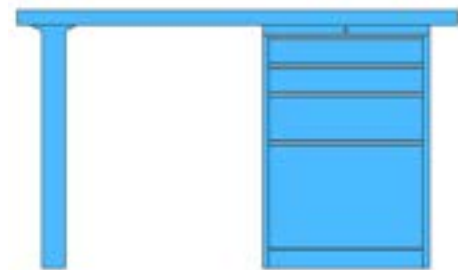
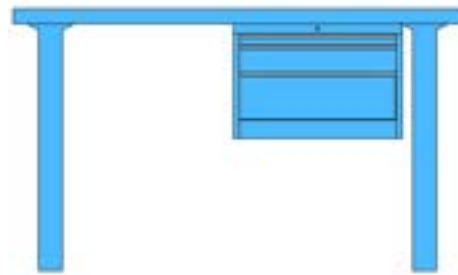

WORKBENCH 20-80

LENGTH= 78.74 in / DEPTH= 31.50 in / HEIGHT= 33.07/33.46 in

SERIES COLOR

Item Code **FBIA37001**

Type of work surface	Metal
Surface thickness	1.57 inches
Capacity in Lb.	1102.31 lb

Steel WORKBENCH thickness from 0.06" to 0.13" Reinforced. After a washing and phosphating treatment, an electrostatic powder coating (suitable for outdoor use) is applied. Certified by the most important paint manufacturers. They may be disassembled for efficient and comfortable transportation. Measures studied for proper ergonomics.

Item Code **FBIA37010**

Type of work surface	Metal
Surface thickness	1.57 inches
Capacity in Lb.	1102.31 lb

Steel WORKBENCH thickness from 0.06" to 0.13" Reinforced. After a washing and phosphating treatment, an electrostatic powder coating (suitable for outdoor use) is applied. Certified by the most important paint manufacturers. They may be disassembled for efficient and comfortable transportation. Measures studied for proper ergonomics.

Item Code **FBIA37016**

Type of work surface	Metal
Surface thickness	1.57 inches
Capacity in Lb.	1763.7 lb

Steel WORKBENCH thickness from 0.06" to 0.13" Reinforced. After a washing and phosphating treatment, an electrostatic powder coating (suitable for outdoor use) is applied. Certified by the most important paint manufacturers. They may be disassembled for efficient and comfortable transportation. Measures studied for proper ergonomics.

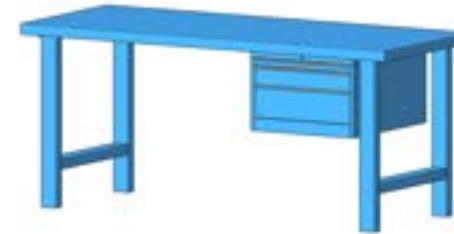

Load capacity is net and refers to uniformly distributed loads.



WORKBENCH 25-80

LENGTH= 98.43 in. / DEPTH= 31.50 in. / HEIGHT= 33.07/33.46 in.

SERIES COLOR



Item Code **FBIA38401**

Type of work surface	Metal
Surface thickness	1.57 inches
Capacity in Lb.	1763.7 lb

Steel WORKBENCH thickness from 0.06" to 0.13" Reinforced. After a washing and phosphating treatment, an electrostatic powder coating (suitable for outdoor use) is applied. Certified by the most important paint manufacturers. They may be disassembled for efficient and comfortable transportation. Measures studied for proper ergonomics.



Item Code **FBIA38404**

Type of work surface	Metal
Surface thickness	1.57 inches
Capacity in Lb.	1763.7 lb

Steel WORKBENCH thickness from 0.06" to 0.13" Reinforced. After a washing and phosphating treatment, an electrostatic powder coating (suitable for outdoor use) is applied. Certified by the most important paint manufacturers. They may be disassembled for efficient and comfortable transportation. Measures studied for proper ergonomics.



Item Code **FBIA38446**

Type of work surface	Metal
Surface thickness	1.57 inches
Capacity in Lb.	1763.7 lb

Steel WORKBENCH thickness from 0.06" to 0.13" Reinforced. After a washing and phosphating treatment, an electrostatic powder coating (suitable for outdoor use) is applied. Certified by the most important paint manufacturers. They may be disassembled for efficient and comfortable transportation. Measures studied for proper ergonomics.

WORKBENCH 30-80

LENGTH= 118.11 in. / DEPTH= 31.50 in. / HEIGHT= 33.07/33.46 in.

SERIES COLOR



Item Code **FBIA59801**

Type of work surface	Metal
Surface thickness	1.57 inches
Capacity in Lb.	1763.7 lb

Steel WORKBENCH thickness from 0.06" to 0.13" Reinforced. After a washing and phosphating treatment, an electrostatic powder coating (suitable for outdoor use) is applied. Certified by the most important paint manufacturers. They may be disassembled for efficient and comfortable transportation. Measures studied for proper ergonomics.



Item Code **FBIA59804**

Type of work surface	Metal
Surface thickness	1.57 inches
Capacity in Lb.	1763.7 lb

Steel WORKBENCH thickness from 0.06" to 0.13" Reinforced. After a washing and phosphating treatment, an electrostatic powder coating (suitable for outdoor use) is applied. Certified by the most important paint manufacturers. They may be disassembled for efficient and comfortable transportation. Measures studied for proper ergonomics.

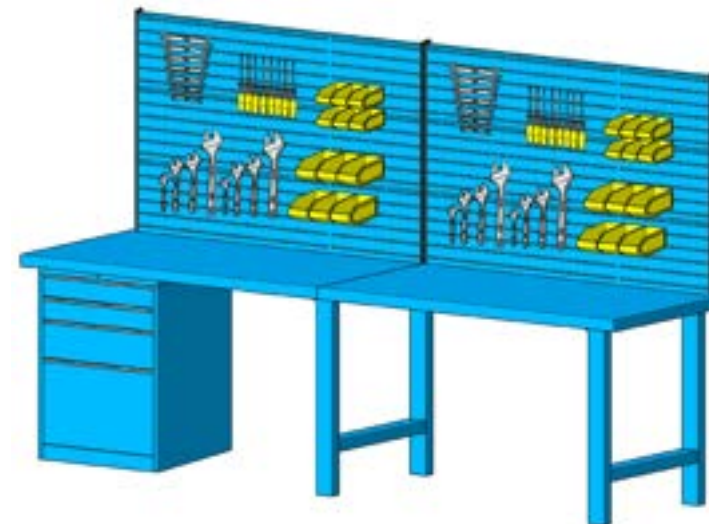

Item Code **FBIG598S1**

Dimensions in inches	118.11x31.50x35.43/72.05 H
Type of work surface	Metal
Thickness in inches	1.57
Capacity in Lb.	1763.7 lb

- Not included: electrical installation, tools and set of drawer dividers
- Load capacity is net and refers to uniformly distributed loads.

Your best choice for operating in multiple sectors!

MOBILE WORKBENCHES

SERIES COLOR

Steel workbench thickness from 0.06" to 0.13". Reinforced. After a washing and phosphating treatment, an electrostatic powder coating (suitable for outdoor use) is applied. Certified by the most important paint manufacturers. They may be disassembled for efficient and comfortable transportation. Measures studied for proper ergonomics. High quality and resistant Ø4.92" swivel casters with brakes.

Item Code	FCA C328 02 04
Dimensions in inches	51.18x31.50x33.07 H
Static Load Capacity	1102.31 lb
Dynamic Load Capacity	440.92 lb
It consists of:	
2 swivel casters with brake Ø4.92" (standard rubber)	
2 rigid casters Ø4.92" (standard rubber)	



Item Code	FCC C328 13 04
Dimensions in inches	51.18x31.50x33.07 H
Static Load Capacity	1102.31 lb
Dynamic Load Capacity	440.92 lb
It consists of:	
2 swivel casters with brake Ø4.92" (standard rubber)	
2 rigid casters Ø4.92" (standard rubber)	
1 DRAWER UNIT with 3 single slide drawers	



Item Code	FCAC34202
Dimensions inches.	59.06x31.50x33.07 H
Static Load Capacity	1102.31 lb
Dynamic Load Capacity	440.92 lb
It consists of:	
2 swivel casters with brake Ø4.92" (standard rubber)	
2 rigid casters Ø4.92" (standard rubber)	



Item Code	FCCC32814
Dimensions in inches	51.18x31.50x85.04 H
Load capacity in lb	485.02 lb
Surface thickness in inches	1.57
It consists of:	
2 swivel casters with brake Ø4.92" (standard rubber)	
2 rigid casters Ø4.92" (standard rubber)	
1 metal cabinet with shutter + 1 set of 52 plastic hooks (tools are not included)	
2 standardized columns + 1 perforated panel	
1 light fixture 2x18W + 1 support	

Load capacity is net and refers to uniformly distributed loads.

Your best choice for operating in multiple sectors!

MOBILE WORKBENCH

SERIES COLOR

Item Code	FCAC34204
Dimensions in inches	59.06 x 31.50 x 33.07 H
Static Load Capacity	1102.31 lb
Dynamic Load Capacity	440.92 lb
It consists of:	
2 swivel casters with brake Ø4.92" (standard rubber)	
2 rigid casters Ø4.92" (standard rubber)	
1 DRAWER UNIT with 3 single slide drawers	

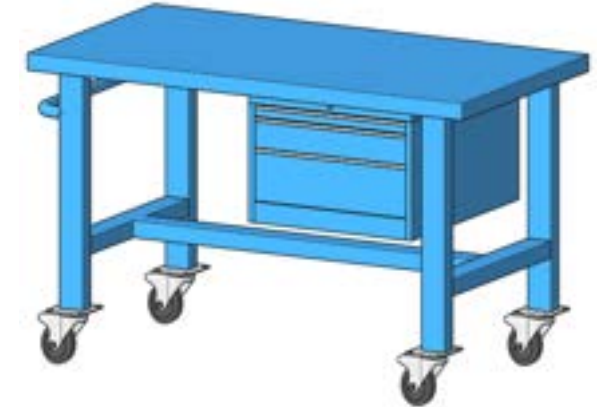

Item Code	FCAC34205
Dimensions inches	60.24 x 31.50 x 35.24 H
Static Load Capacity	1102.31 lb
Dynamic Load Capacity	440.92 lb
It consists of:	
2 2 swivel casters with brake Ø4.92" (standard rubber) 2 rigid casters Ø4.92" (standard rubber)	
2 height adjustable legs	



Item Code	FCAC37002
Dimensions inches.	78.74 x 31.50 x 33.07 H
Static Load Capacity	1102.31 lb
Dynamic Load Capacity	440.92 lb
It consists of:	
2 swivel casters with brake Ø4.92" (standard rubber)	
2 rigid casters Ø4.92" (standard rubber)	



Item Code	FCAC37004
Dimensions inches.	78.74x31.50x33.07 H
Static Load Capacity	1102.31 lb
Dynamic Load Capacity	440.92 lb
It consists of:	
2 swivel casters with brake Ø4.92" (standard rubber)	
2 rigid casters Ø4.92" (standard rubber)	
1 DRAWER UNIT with 3 single slide drawers	

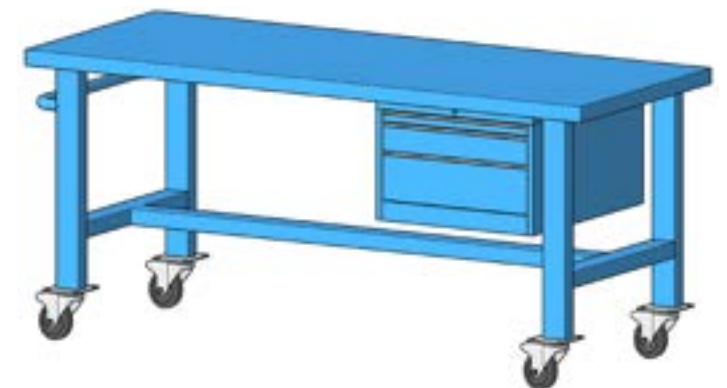

Your best choice for operating in multiple sectors!

MOBILE WORKBENCH

SERIES COLOR

Item Code	FCAC37005
Dimensions in inches	78.74x31.50x33.07 H
Static Load Capacity	1102.31 lb
Dynamic Load Capacity	440.92 lb
It consists of:	
2 swivel casters with brake Ø4.92" (standard rubber)	
2 rigid casters Ø4.92" (standard rubber)	
2 height adjustable legs	



CABINET ACCESSORIES FOR YOUR NEEDS

Item Code	Dimensions
FBIA32800	51.18" x 31.5" x 1.57"
FBIA34200	59.06" x 31.5" x 1.57"
FBIA37000	78.74" x 31.5" x 1.57"
FBIA38400	98.43" x 31.5" x 1.57"
FBIA59800	118.11" x 31.5" x 1.57"



REINFORCED DRAWER UNITS



Item Code	Dimensions inches.	Drawers
FDD107055	22.2x28.58x31.50 H	4
DRAWER UNIT with 4 single slide drawers		
Load capacity per drawer: 220.46 lb		



Item Code	Dimensions inches.	Drawers
F DD103052	22.20x28.58x15.08 H	3
DRAWER UNIT with 3 single slide drawers		
Load capacity per drawer: 220.46 lb		



FIXED LEG

Item Code	Dimensions
FBL 6025 00	3.15" x 28.15" x 31.50" H



HEIGHT ADJUSTABLE LEG

Item Code	Dimensions
FBL 6045 00 58	3.15" x 28.15" x 27.56" / 43.31" H



LEG WITH WHEELS

Item Code	Dimensions
FBL 6075 A0	31.50 inches
It has: 2 rigid casters Ø4.92" - Standard rubber	



HEIGHT ADJUSTABLE LEG WITH WHEELS

Item Code	Dimensions
FBL 6055 A0 58	33.46/49.21 inches
It has: 2 rigid casters Ø4.92" - Standard rubber	

WORKBENCH CROSSBARS



Item Code	Workbench Crossbar Size
FBL 6605 00	51.18 inches

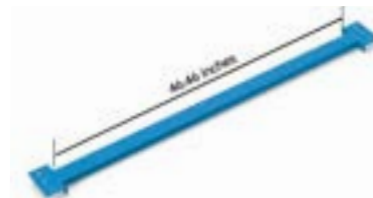

Item Code	Workbench Crossbar Size
FBL 6610 00	59.06 inches



Item Code	Workbench Crossbar Size
FBL 6620 00	78.74 inches



Swivel caster with brake



Swivel caster without brake



Steel handle



Height adjustable leg

All panels have a folded and welded steel structure, made of the type of galvanized steel sheet used in the automotive industry, becoming more resistant and with a longer lifespan. Before being painted, they are subject to a washing and phosphating treatment. Later, an electrostatic powder coating is applied. Application of the polyurethane paint makes them suitable for outdoor use. They have been certified by the most important paint manufacturers, ensuring their quality and durability.

WORKBENCHES -LOOK 10

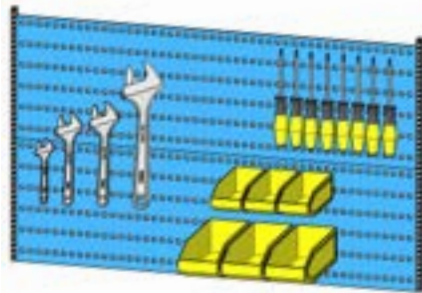

Item Code	FBL A010 03 04
To be used in	Workbenches
2 Columns 24.88H inches	
2 TOOL PANELS 38.27x11.97 H inches	
Containers, tools and hooks are not included	

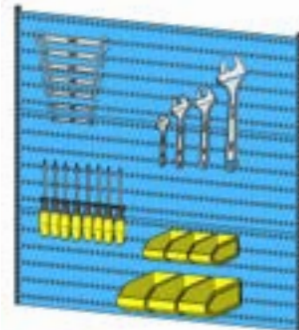

Item Code	FBL A010 04 04
To be used in	Workbenches
2 Standardized columns 36.85 inches	
3 perforated tool panels 38.27x11.97 H inches	
Containers, tools and hooks are not included	

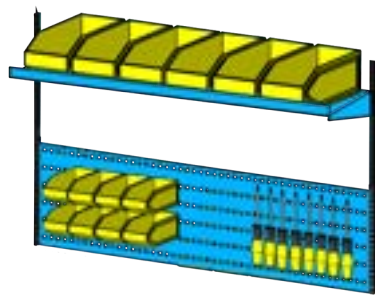

Item Code	FBL A110 05 04
To be used in	Workbenches
2 Standardized columns 24.88 H inches	
1 shelf tray 37.60x8.66 inches	
1 perforated tool panel 38.27x11.97 H inches	
1 articulated arm with PRACTIBOX containers	
Containers, tools and hooks are not included	

WORKBENCHES -LOOK 15

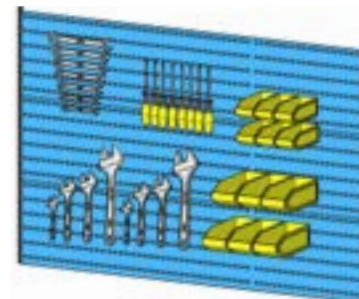

Item Code	FBL A015 07 04
To be used in	Workbenches
2 upright posts 36.85 inches	
2 perforated panels 57.36x11.97 H inches	
Containers, tools and hooks are not included	

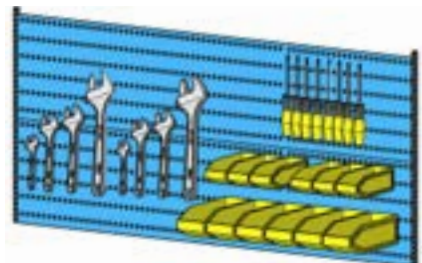

Item Code	FBL A015 06 04
To be used in	Workbenches
2 Columns 24.88 H inches	
2 perforated panels 57.36x11.97 inches	
Containers, tools and hooks are not included	

WORKBENCHES -LOOK 10

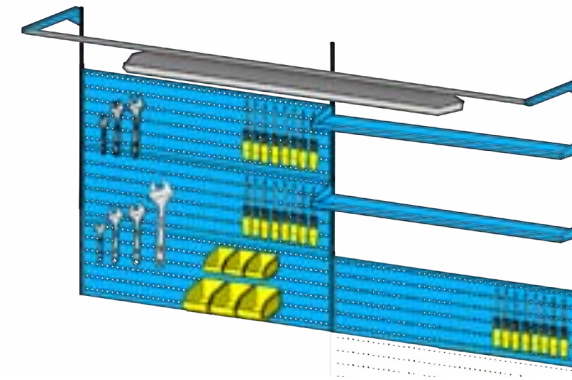

Item Code	FBL A120 13 04
To be used in	Workbenches
3 Columns 48.82 in H	
1 tray 37.6 x 8.66 in; 1 tray 37.60x12.60 in	
4 TOOL PANELS 38.27x11.97 in H	
1 light fixture support	
1 Phillips lamp 2x36 W (installation is not included)	
Containers, tools and hooks are not included	

WORKBENCHES -LOOK 15

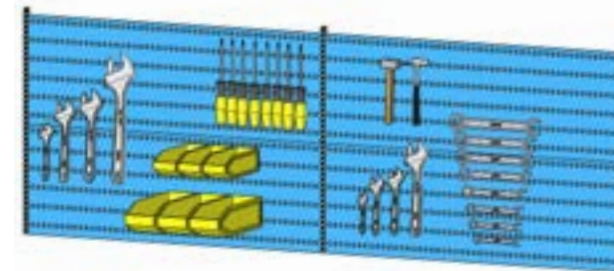

Item Code	FBL A020 07 04
To be used in	Workbenches
3 upright posts 24.88 in H	
4 perforated panels 38.27x11.97 in H	
Accessories and hooks are not included	

WORKBENCHES -LOOK 20

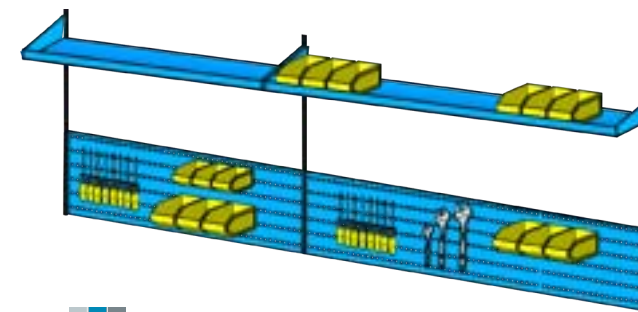

Item Code	FBL A025 06 04
To be used in	Workbenches
3 Columns 24.88 in H	
1 tray 56.69 x 8.66 in; 1 tray 37.6 x 8.66 in	
1 TOOL PANEL 38.27 x 11.97 in H	
1 TOOL PANEL 57.36 x 11.97 in H	
Containers, tools and hooks are not included	

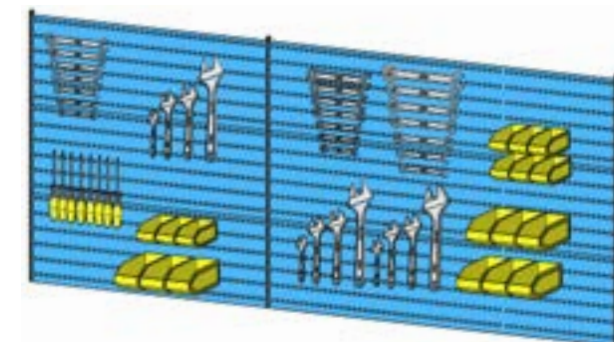

Item Code	FBL A025 08 04
To be used in	Workbenches
3 Panels 36.85 in H	
3 Perforated panels 38.27 x 11.97 in H	
3 Perforated panels 57.36 x 11.97 in H	
Containers, tools and hooks are not included	

Storage Compat new and lightweight wall panels can be joined together by any of their sides (wide side or long side) to be installed in the most suitable way according to the space available. Therefore, you can configure a wall with perforated panels to hang tools, utensils or any other element you may require.



Item Code	FBL 1220 51
To be used in	Walls
1 - perforated panel FBL122000	
4 - wall anchors	
4 - 8" screws	
2 - galvanized 1PLZ bin supports	
2 - ZEUS Series bins 1PLZ	
1 set of RHINO plastic hooks	
Containers, tools and hooks are not included	



Item Code	FBL 1230 51
To be used in	Walls
2 - perforated panels 118.11 x 196.85 in	
1 - set of 52 RHINO plastic hooks	
2 - ZEUS Series bins 1PLZ	
2 - galvanized 1PLZ bin supports	
2 - M6 screws	
4 - 0.31" wall anchors	
4 - 3/4" screws	



Item Code	FBL 1240 51
To be used in	Walls
4 - perforated panels 118.11 x 196.85 in	
2 - sets of 52 RHINO plastic hooks	
2 - ZEUS Series bins 1PLZ	
2 - galvanized 1PLZ bin supports	
2 - M6 screws	
2 - M6 zinc plated nuts	
8 - 0.31" wall anchors	
8 - 3/4" screws	

You may combine them in different ways!

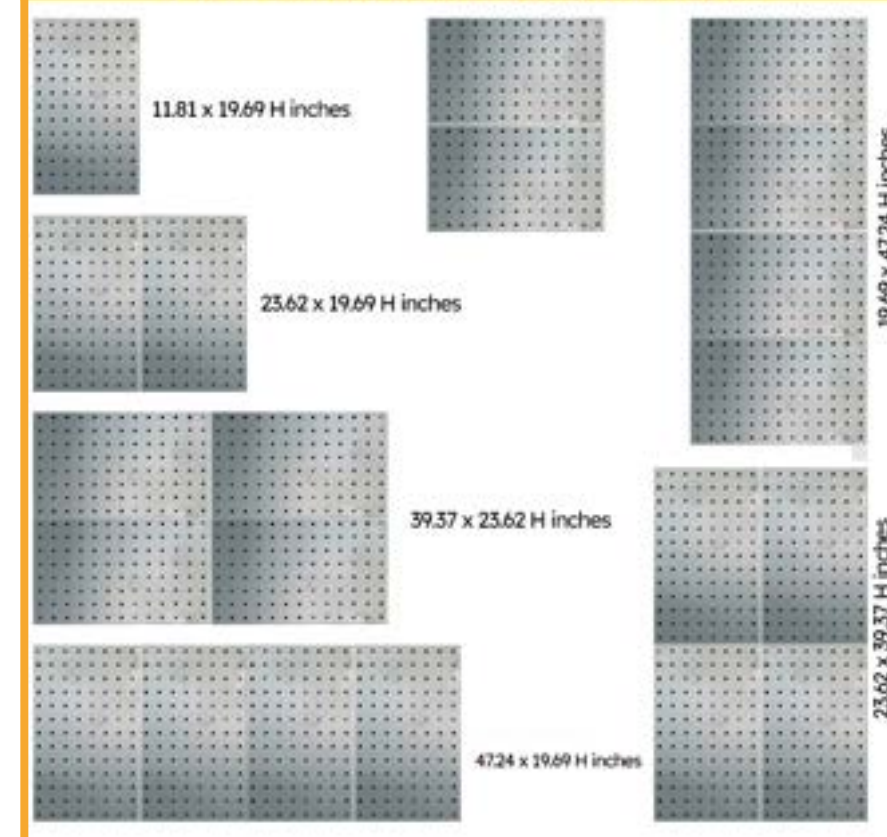

Easy to join

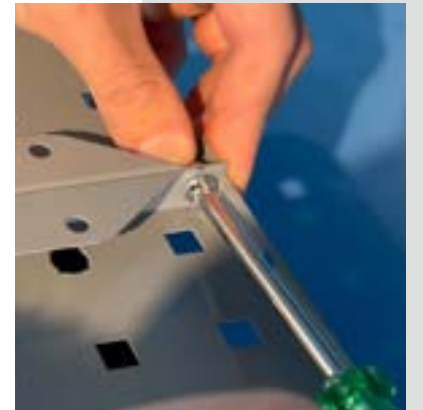

BRAND NEW PRODUCT!

Workbench Shelving Unit

Revolutionize your workspace with our Workbench Shelving Unit 1PLZ meticulously designed to optimize space in compact environments. Equipped with two sturdy painted lateral sides, four galvanized steel trays, and 24 ZEUS plastic bins, this shelving unit offers an intelligent solution to organize your tools and materials.



Available colors



Item Code **FLCC10052**

- To be installed on **WALLS and WORKBENCHES**
- 2 shelving unit lateral sides Code FLCC10001 (17.8 x 8.86 x 0.03 in)
- 4 metal shelf for shelving unit 1PLZ (1.57 x 6.69 x 0.59 H in)
- 16 M6 screws and 16 0.24" in. rivet nuts
- 24 ZEUS Plastic bins 1PLZ (6.30 x 3.54 x 2.95 x 2.95 in)
- 8 RHINO plastic hooks
- Total load capacity on the bench: 165.35 lbs
- Total load capacity on the wall: 88.18 lbs
- Distance from the top edge to the hole edge for wall mounting: 2.48 in



Handle to carry the shelving unit



Wall mounting holes



Holes for RHINO plastic hooks

RHINO
Plastic Hooks



Explore these innovative mounting Rhino plastic hooks, designed to be used without screws and made of high-resistant recycled plastic previously used in car bumpers. These hooks represent a practical solution, and they also contribute to environmental preservation, as they are a sustainable alternative for organizing your space. With their versatile and affordable design, these hooks offer an exceptional performance, and they are a cost-saving alternative for your storage needs.

Set of tool panel hooks

Set of 52 RHINO plastic hooks

Item Code	Nylon Bag 3.94 x 7.87 x 0.01 inches
FBL954000	1

Basic Hook Set

Item Code	Set of 52 hooks FBL954000	High Power Magnet
FBL950800	1	2

Full Hook Set

Item Code	Set of 52 hooks FBL954000	Oil Tray Hook	High Power Magnet
FBL953000	2	1	3

Premium Hook Set

Item Code	Set of 52 hooks FBL954000	Oil Tray Hook	High Power Magnet	ZEUS Bin Support	ZEUS Bins
FBL958000	3	1	6	2	2



Perforated panel fixing



Suitable for any type of tools



Multiple positions

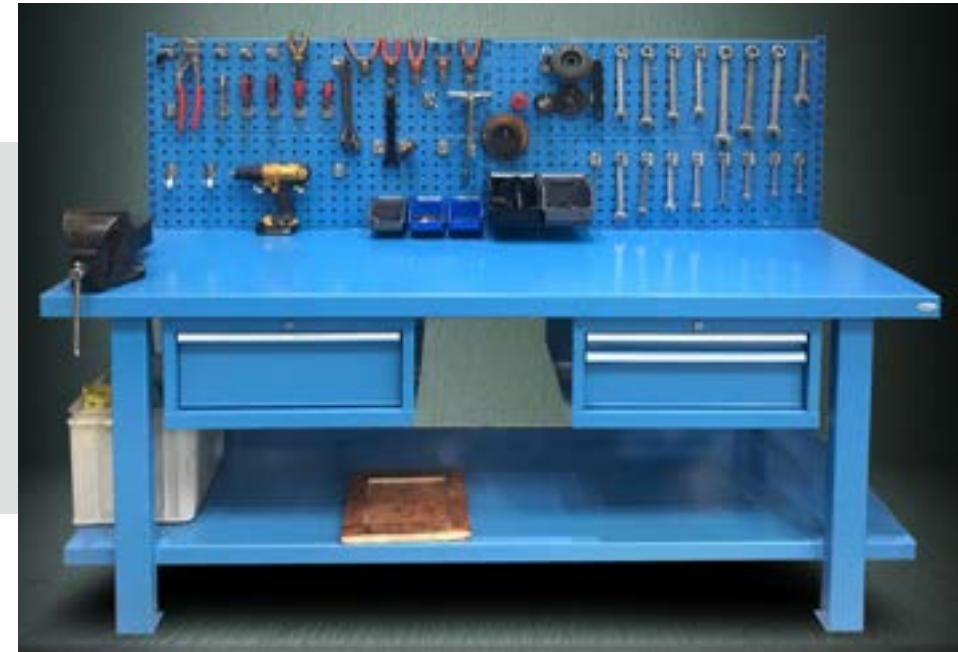

Steel workbenches are made with a folded and welded galvanized structure, similar to that used in the automotive industry, making them more resistant and with a longer lifetime. Before being painted, they are subject to a washing and phosphating treatment. Later, an electrostatic powder coating is applied. Application of the polyurethane paint makes them suitable for outdoor use. They have been certified by the most important paint manufacturers, ensuring their quality and durability.



Item Code	FBG A420 00 01
Dimensions	78.74 x 29.53 x 34.65 h in
Upper surface load capacity:	4409.25 lbs
Lower surface load capacity:	771.62 lbs



Item Code	FBG A420 03 01
Dimensions	78.74 x 29.53 x 34.65 h in
Full with metal DRAWER UNIT	
Upper surface load capacity:	4409.25 lbs
Lower surface load capacity:	771.62 lbs

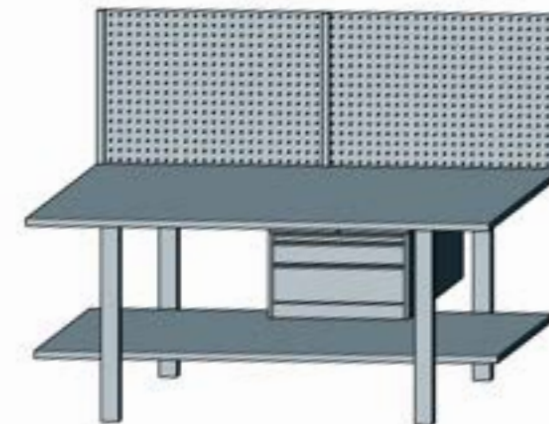

Full with DRAWER UNIT, panel and hook set

Item Code	FBG A420 53 01
Dimensions	78.74 x 31.50 x 59.65 H in
Full with metal DRAWER UNIT + Tool Panel	
Upper surface load capacity:	4409.25 lbs
Lower surface load capacity:	771.62 lbs

Bin Cabinets

Steel cabinets for plastic bins are the ideal solution to store different materials. They are indispensable in factory facilities, offices, warehouses and laboratories. Bin cabinets are made with a folded and welded steel structure, with the type of galvanized steel sheet used in the automotive industry, making them more resistant and with a longer lifetime. Galvanized treatment of laminated steel, together with the washing and phosphating treatment before painting, ensures a surface suitable for receiving a high-standard electrostatic polyurethane powder coating, providing the best protection. This means that they can be used, for example, in aggressive and humid environments.

These cabinets can have a diverse number of work surfaces or shelves, depending on the plastic containers distribution. Furthermore, they can have swinging doors with magnets, eliminating the need to lock the doors during working hours to keep them closed. Their concealed hinges help prevent tampering with the door. The combination lock features a triple latch, and there is a master key available, offering dual rotation and three-point locking.



Item Code FAK 2040 51 04

Dimensions en inches	27.56 x 10.63 x 40.55 H
Load capacity	992.08 lbs

Metal cabinet with 8 shelves. Depth: 9.25 in. (110.23 lbs)

54 black plastic bins Model 1 PLZ (Dim. 6.30"x3.74"x2.95" H in)



Item Code FAK 2040 52 04

Dimensions en inches	27.56 x 10.63 x 40.55 H
Load capacity	992.08 lbs

Metal cabinet with 6 shelves. Depth: 9.25 in (110.23 lbs)

24 black plastic bins Model 1PLZ (Dim. 6.30"x3.74"x2.95" H in) and 12 plastic bins 2 PLZ (Dim. 9.06" x 7.87" x 5.51" H)



Item Code FAK 1040 51 04

Dimensions en inches	27.56 x 10.63 x 40.55 H
Load capacity	992.08 lbs

Metal cabinet with 8 shelves. Depth: 9.25 in (110.23 lbs)

54 black plastic bins Model 1 PLZ. (Dim. 6.30"x3.74"x2.95" H in)



Item Code FAK 2040 53 04

Dimensions en inches	27.56 x 10.63 x 40.55 H
Load capacity	992.08 lbs
Metal cabinet with 5 shelves. Depth: 9.25 in (110.23 lbs)	
24 black plastic bins Model 2 PLZ (Dim. 9.06" x 7.87" x 5.51" H)	

Item Code FAK 1040 53 04

Dimensions en inches	27.56 x 10.63 x 40.55 H
Load capacity	992.08 lbs
Metal cabinet with 5 shelves. Depth: 9.25 in (110.23 lbs)	
24 black plastic bins Model 2 PLZ (Dim. 9.06" x 7.87" x 5.51" H)	

Item Code FAK 1040 52 04

Dimensions en inches	27.56 x 10.63 x 40.55 H
Load capacity	992.08 lbs
Metal cabinet with 6 shelves. Depth: 9.25 in (110.23 lbs)	
24 black plastic bins Model 1 PLZ (Dim. 6.30"x3.74"x2.95" H in) and 12 plastic bins Med. 2PLZ (Dim. 9.06" x 7.87" x 5.51" H)	



Item Code . 2066 54 04

Dimensions in inches	27.56 x 10.63 x 66.34 H
Load capacity	1102.31 lbs
Cabinet with 11 shelves. Depth: 9.25 in (110.23 lbs)	
30 black bins Model 1 PLZ (Dim. 6.30"x3.74"x2.95" H in)	
28 black bins Model 2 PLZ (Dim. 9.06" x 7.87" x 5.51" H in)	

Item Code . 1066 54 04

Dimensions in inches	27.56 x 10.63 x 66.34 H
Load capacity	1102.31 lbs
Cabinet with 11 shelves. Depth: 9.25 in (110.23 lbs)	
30 black bins Model 1 PLZ (Dim. 6.30"x3.74"x2.95" H in)	
28 black bins Model 2 PLZ (Dim. 9.06" x 7.87" x 5.51" H in)	

Item Code . 1066 63 04

Dimensions in inches	27.56 x 10.63 x 66.34 H
Load capacity	1102.31 lbs
Cabinet for PRACTIBOX Containers	
2 Item FPG10710101; 4 Item FPG15710101, 3 Item FPG20710101; 1 Item FPG25710101, 1 Item FPG30710101	

ADJUSTABLE SHELF DEPTH: 9.25 in



Item Code FAK 9020 01 99

Dimensions in inches.	26.57 x 9.25 x 0.67 H in
Full with 4 hooks	
The surface depth is suitable for containers: Model 1 PLZ/Model 2 PLZ	
Load capacity: 110.23 lbs	



Item Code FAK 2080 52 04

Dimensions in inches	27.56x10.63x79.92 H
Load capacity	1102.31 lbs
Cabinet with 14 shelves. Depth: 9.25 in (110.23 lbs)	
42 black bins Model 1 PLZ (Dim. 6.30"x3.74"x2.95" H in)	
32 black bins Model 2 PLZ (Dim. 9.06" x 7.87" x 5.51" H in)	

Item Code FAK 1080 52 04

Dimensions in inches	27.56x10.63x79.92 H
Load capacity	1102.31 lbs
Cabinet with 14 shelves. Depth: 9.25 in (110.23 lbs)	
42 black bins Model 1 PLZ (Dim. 6.30"x3.74"x2.95" H in)	
2 swinging doors	
32 black bins Model 2 PLZ (Dim. 9.06" x 7.87" x 5.51" H in)	

Item Code FAK 1080 58 04

Dimensions in inches	27.56x10.63x79.92 H
Load capacity	1102.31 lbs
Cabinet for PRACTIBOX Containers	
1 Item FPG 1071 01 01, 6 Item FPG 1571 01 01, 2 Item FPG 2071 01 01, 2 Item FPG 2571 01 01, 1 Item. FPG 3071 01 01	



Easily accessible

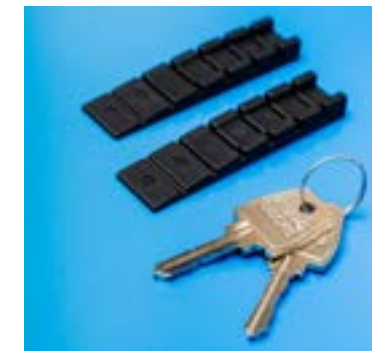

Stabilizers and a set of keys are included



Ergonomic door handles



Adjustable surfaces



High Power Magnet



PRACTIBOX bin fitting device.

TOOL CABINETS

Discover the most efficient storage solution



Metal cabinets with swinging doors. Cutting-edge technologies and high-quality materials are used to manufacture the tool cabinets. They are assembled with a folded and welded steel structure -the type of galvanized steel sheet commonly found in the automotive industry, becoming more resistant and with a longer lifespan. After a washing and phosphating treatment, an electrostatic powder coating is applied. Application of the polyurethane paint makes them suitable for outdoor use.

They have been certified by the most important paint manufacturers. Their swinging doors have been designed with a high power magnet, eliminating the need to lock them during working hours to keep them closed. Their concealed hinges help prevent tampering with the door. They adapt to any demand, turning an excellent storage solution for any kind of materials. They are versatile, robust, modular, and can include drawers, panels, shelves and many other accessories. The combination lock features a triple latch with a master key available, offering dual rotation and threepoint locking.



As they have been manufactured with galvanized folded steel, commonly found in the automotive industry, tool cabinets are sturdy and resistant to elements that are naturally aggressive to materials. A galvanized treatment of laminated steel, together with the washing and phosphating treatment before painting, ensures a surface suitable for receiving a high-standard electrostatic polyurethane powder coating providing the best protection. This means that they can be used, for example, in aggressive and humid environments.



Versatile, robust and modular. Tool cabinets are the perfect solution for efficiently organizing and storing materials in factories, offices and warehouses.

Item Code	FAA 1100 00
Dimensions in inches	20.16 x 21.85 x 39.37 H
Inner dimensions in inches	19.57 x 19.69 x 33.46 H
Load capacity	1322.77 lbs UDL
Top, middle and bottom three-point lock	
Concealed hinges to prevent tampering with the door	



ACCESSORIES
Spare key. Please, always specify the number appearing in the door lock.



Item Code	FAA 1200 00
Dimensions in inches	40.28 x 21.85 x 39.37 H
Inner dimensions in inches	39.17 x 19.69 x 33.46 H
Load capacity	1322.77 lbs UDL
Top, middle and bottom three-point lock	
Concealed hinges to prevent tampering with the door	



Item Code	FAA 1200 51
Dimensions in inches	40.28 x 21.85 x 39.37 H
Load capacity	1322.77 lbs UDL
Cabinet with 2 trays. Depth: 19.69" in (220.46 lbs)	
Top, middle and bottom three-point lock	
Concealed hinges to prevent tampering with the door	
4 black bins model zeus 4 plz	



Item Code	FAA 1200 52
Dimensions in inches	40.28 x 21.85 x 39.37 H
Load capacity	1322.77 lbs UDL
Cabinet with 2 trays. Depth: 19.69" in (220.46 lbs)	
1 single slide metal drawer (110.23 lbs)	
3 black bins model ZEUS 4 plz	
Top, middle and bottom three-point lock.	
Concealed hinges to prevent tampering with the door	



Item Code	FAA 1200 55
Dimensions in inches	40.28 x 21.85 x 39.37 H
Load capacity	1322.77 lbs UDL
Cabinet with 1 trays. Depth: 19.69" in (220.46 lbs)	
2 single slide metal drawers (110.23 lbs)	
3 black bins model ZEUS 4 plz	
Top, middle and bottom three-point lock	
Concealed hinges to prevent tampering with the door	



EMPTY CABINET WITH SWINGING DOORS



Item Code	FAA 1300 00
Dimensions in inches	40.28" x 15.75" x 78.74" H
Load capacity	1763.7 lbs. UDL
Inner dimensions in inches:	39.17" x 13.58" x 72.83" H

Item Code	FAA 1400 00
Dimensions in inches	40.28" x 21.85" x 78.74" H
Load capacity	1763.7 lbs. UDL
Inner dimensions in inches:	39.17" x 19.69" x 72.83" H

EMPTY CABINET WITH SWINGING DOORS AND PERFORATED PANELS



Item Code	FAA 1303 00 04
Dimensions in inches	40.28" x 15.75" x 78.74" H
Load capacity	1763.7 lbs. UDL
Inner dimensions in inches:	39.17" x 13.58" x 72.83" H

Item Code	FAA 1403 00 04
Dimensions in inches.	40.28 x 21.85 x 78.74 h in
Load capacity	1763.7 lbs. UDL
Inner dimensions in inches:	39.17" x 19.69" x 72.83" H

EMPTY 0.12" In. POLYCARBONATE CABINET WITH SWINGING DOORS



Item Code	FAA 1302 00
Dimensions in inches	40.28" x 15.75" x 78.74" H
Load capacity	1763.7 lbs. UDL
Inner dimensions in inches:	39.17" x 13.58" x 72.83" H

Item Code	FAA 1402 00 04
Dimensions in inches	40.28 x 21.85 x 78.74 h in
Load capacity	1763.7 lbs. UDL
Inner dimensions in inches:	39.17" x 19.69" x 72.83" H

Hinges to prevent tampering with the door



Compatible with ZEUS series bins

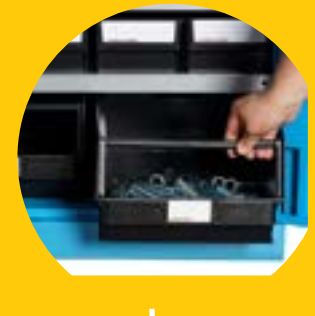

Tool panels can be added



High power magnet to prevent doors from opening unintentionally



Stabilizers and keys



Drawers with telescopic slides



Height adjustable shelves



Ergonomic handle

Item Code	FAA 1300 01
Dimensions in inches	40.28" x 15.75" x 78.74" H
Load capacity	1763.7 lbs. UDL
It includes a 40.28x15.75x78.74 H in cabinet	
4 height adjustable, boltless fitting shelves, 13.58 in depth, 220.46 lbs UDL each	
Top, middle and bottom three-point lock	
Concealed hinges to prevent tampering with the door	
Delivered with plastic stabilizers	



Item Code	FAA 1303 52
Dimensions in inches	40.28 x 15.75 x 78.74 H
Load capacity	1763.7 lbs. UDL
It includes a 40.28x15.75x78.74 H in cabinet	
1 height adjustable, boltless fitting shelves, 9.84 in depth, 220.46 lbs UDL each	
4 perforated panels (38.90" x 0.51" x 17.95" H in)	
2 swinging metal doors with perforated panels	
Top, middle and bottom three-point lock	
Concealed hinges to prevent tampering with the door	
Hook Set for 133 tools	
Delivered with plastic stabilizers	

Item Code	FAA 1300 52
Dimensions in inches	40.28" x 15.75" x 78.74" H
Load capacity	1763.7 lbs. UDL
It includes a 40.28" x 15.75" x 78.74" H in cabinet	
6 height adjustable, boltless fitting shelves, 13.58 in depth, 220.46 lbs UDL each	
28 black containers model Zeus 3PLZ	
Top, middle and bottom three-point lock	
Concealed hinges to prevent tampering with the door	
Delivered with plastic stabilizers	



Item Code	FAA 1400 01
Dimensions in inches	40.28" x 21.85" x 78.74" H
Load capacity	1763.7 lbs
It includes a 40.28" x 21.85" x 78.74" h in cabinet	
4 height adjustable, boltless fitting shelves, 19.69" in depth, 220.46 lbs UDL each	
Top, middle and bottom three-point lock	
Concealed hinges to prevent tampering with the door	
Delivered with plastic stabilizers	

Item Code	FAA 1302 03 04
Dimensions in inches	40.28 x 15.75 x 78.74 H.
Load capacity	1763.7 lbs. UDL
It includes a 40.28" x 15.75" x 78.74" cabinet, with clear high impact acrylic doors.	
4 height adjustable, boltless fitting shelves, 13.58 in depth, 220.46 lbs UDL each	
Top, middle and bottom three-point lock	
Concealed hinges to prevent tampering with the door	
Delivered with plastic stabilizers	



Item Code	FAA 1400 02
Dimensions in inches.	40.28" x 21.85" x 78.74" H
Load capacity	1763.7 lbs. UDL
It includes a 40.28" x 21.85" x 78.74" h in cabinet	
4 height adjustable, boltless fitting shelves, 19.69" in depth, 220.46 lbs UDL each	
3 single slide drawers, with a load capacity of 110.23 lbs, height adjustable, boltless fitting, and a white label holder with clear vinyl protection	
Top, middle and bottom three-point lock	
Concealed hinges to prevent tampering with the door	
Delivered with plastic stabilizers	

Item Code	FAA 1400 07
Dimensions in inches.	40.28" x 21.85" x 78.74" H
Load capacity	1763.7 lbs. UDL
It includes a 40.28" x 21.85" x 78.74" h in cabinet	
4 height adjustable, boltless fitting shelves, 19.69" in depth, 220.46 lbs UDL each	
1 single slide drawer, load capacity of 110.23 lbs, height adjustable, boltless fitting, and a white label holder with clear vinyl protection	
Top, middle and bottom three-point lock	
Concealed hinges to prevent tampering with the door	
Delivered with plastic stabilizers	



Item Code	FAA 1400 08 EF
Dimensions in inches.	40.28" x 21.85" x 78.74" H
Load capacity	1763.7 lbs. UDL
It includes a 40.28" x 21.85" x 78.74" h in cabinet	
4 height adjustable, boltless fitting shelves, 19.69" in depth, 220.46 lbs UDL each	
2 single slide drawers, with a load capacity of 110.23 lbs, height adjustable, boltless fitting, and a white label holder with clear vinyl protection	
Top, middle and bottom three-point lock	
Concealed hinges to prevent tampering with the door	
Delivered with plastic stabilizers	



Item Code	FAA 1400 11
Dimensions in inches.	40.28" x 21.85" x 78.74" H
Load capacity	1763.7 lbs. UDL
It includes a 40.28" x 21.85" x 78.74" h in cabinet	
2 height adjustable, boltless fitting shelves, 19.69" in depth, 220.46 lbs UDL each	
9 single slide drawers, with a load capacity of 110.23lb, height adjustable, boltless fitting, and a white label holder with clear vinyl protection.	
Top, middle and bottom three-point lock	
Concealed hinges to prevent tampering with the door	
Delivered with plastic stabilizers	



Item Code	FAA 1400 63
Dimensions in inches.	40.28" x 21.85" x 78.74" H
Load capacity	1763.7 lbs
It includes a 40.28" x 21.85" x 78.74" h in cabinet	
6 height adjustable, boltless fitting shelves, 19.69" in depth, 220.46 lbs UDL each	
21 bins ZEUS 4 PLZ with crossbar (Dim. 19.69" x 11.81" x 7.87" H in) Capacity 7.40 gal.)	
Top, middle and bottom three-point lock	
Concealed hinges to prevent tampering with the door	
Delivered with plastic stabilizers	

Item Code	FAA 1400 65
Dimensions in inches.	40.28" x 21.85" x 78.74" H
Load capacity	1763.7 lbs
It includes a 40.28" x 21.85" x 78.74" h in cabinet	
11 height adjustable, boltless fitting shelves, 19.69" in depth, 220.46 lbs UDL each	
66 MULTIBOX RK5016 plastic containers (Dim. 19.69" x 6.30" x 3.94" H in)	
3 ZEUS containers 4 PLZ with crossbar (Dim. 19.69" x 11.81" x 7.87" H in) Capacity 7.40 gal.)	
Top, middle and bottom three-point lock	
Concealed hinges to prevent tampering with the door	
Delivered with plastic stabilizers	



Item Code	FAA 1402 01
Dimensions in inches.	40.28" x 21.85" x 78.74" H
Load capacity	1763.7 lbs
It includes a 40.28" x 21.85" x 78.74" h in cabinet	
4 height adjustable, boltless fitting shelves, 19.69" in depth, 220.46 lbs UDL each	
Clear swinging doors with a metal frame and a high impact polycarbonate window	
Top, middle and bottom three-point lock	
Concealed hinges to prevent tampering with the door	
Delivered with plastic stabilizers	



Item Code	FAA 1402 52
Dimensions in inches.	40.28" x 21.85" x 78.74" H
Load capacity	1763.7 lbs
It includes a 40.28" x 21.85" x 78.74" h in cabinet	
2 height adjustable, boltless fitting shelves, 19.69" in depth, 220.46 lbs UDL each	
2 perforated panels (38.9" x 0.51" x 17.95" H in)	
Hook Set for 66 tools	
Clear swinging doors with a metal frame and a high impact polycarbonate window	
Top, middle and bottom three-point lock	
Concealed hinges to prevent tampering with the door	
Delivered with plastic stabilizers	



Item Code	FAA 1402 54
Dimensions in inches.	40.28" x 21.85" x 78.74" H
Load capacity	1763.7 lbs
It includes a 40.28" x 21.85" x 78.74" h in cabinet	
4 height adjustable, boltless fitting shelves, 19.69" in depth, 220.46 lbs UDL each	
2 perforated panels (38.90" x 0.51" x 17.95" H in)	
Hook Set for 66 tools	
12 ZEUS containers 4 PLZ with crossbar (Dim. 19.69"/17.72" x 11.81" x 7.87" h in) (Capacity 7.40 gal.)	
Clear swinging doors with a metal frame and a high impact polycarbonate window	
Top, middle and bottom three-point lock	
Concealed hinges to prevent tampering with the door	
Delivered with plastic stabilizers	



Item Code	FAA 1402 55
Dimensions in inches.	40.28" x 21.85" x 78.74" H
Load capacity	1763.7 lbs
It includes a 40.28" x 21.85" x 78.74" h in cabinet	
2 height adjustable, boltless fitting shelves, 19.69" in depth, 220.46 lbs UDL each	
2 perforated panels (38.9" x 0.51" x 17.95" H in)	
Hook Set for 66 tools	
3 single slide drawers, with a load capacity of 110.23 lbs, height adjustable, boltless fitting, and a white label holder with clear vinyl protection.	
Clear swinging doors with a metal frame and a high impact polycarbonate window	
Concealed hinges to prevent tampering with the door	
Delivered with plastic stabilizers	



Item Code	FAA 1402 56
Dimensions in inches.	40.28" x 21.85" x 78.74" H
Load capacity	1763.7 lbs
It includes a 40.28" x 21.85" x 78.74" h in cabinet	
1 height adjustable, boltless fitting shelves, 19.69" in depth, 220.46 lbs UDL each	
3 perforated panels (38.9" x 0.51" x 17.95" H in)	
Hook Set for 66 tools	
4 single slide drawers, with a load capacity of 110.23 lbs, height adjustable, boltless fitting, and a white label holder with clear vinyl protection.	
Clear swinging doors with a metal frame and a high impact polycarbonate window	
Top, middle and bottom three-point lock	
Concealed hinges to prevent tampering with the door	
Delivered with plastic stabilizers	

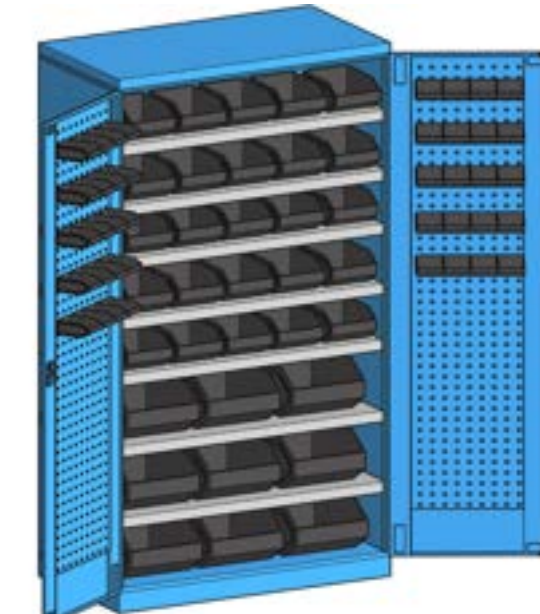

Item Code	FAA 1403 51
Dimensions in inches.	40.28" x 21.85" x 78.74" H
Load capacity	1763.7 lbs
It includes a 40.28" x 21.85" x 78.74" h in cabinet	
5 height adjustable, boltless fitting shelves, 13.58" in depth, 220.46 lbs UDL each	
2 height adjustable, boltless fitting shelves, 19.69" in depth, 220.46 lbs UDL each	
CMV10010 ZEUS bin support 1PLZ	
48 ZEUS containers 1PLZ (Dim. 6.30"/5.51" x 3.74" x 2.95" H in) (Capacity 0.26 gal.)	
5 ZEUS containers 2PLZ (Dim. 9.06"/7.87" x 5.51" x 5.12" H in) (Capacity 1.00 gal.)	
20 ZEUS containers 3A2PLZ (Dim. 13.78"/11.81" x 7.87" x 5.71" H in) (Capacity 2.48 gal.)	
9 ZEUS containers 4PLZ (Dim. 19.69"/17.72" x 11.81" x 7.87" H in) (Capacity 7.40 gal.)	
Top, middle and bottom three-point lock	
Concealed hinges to prevent tampering with the door	
Delivered with plastic stabilizers	



Item Code	FAA 1403 55
Dimensions in inches.	40.28" x 21.85" x 78.74" H
Load capacity	1763.7 lbs
It includes a 40.28" x 21.85" x 78.74" h in cabinet	
4 height adjustable, boltless fitting shelves, 9.84" in depth, 220.46 lbs UDL each	
3 height adjustable, boltless fitting shelves, 13.58" in depth, 220.46 lbs UDL each	
1 height adjustable, boltless fitting shelves, 19.69" in depth, 220.46 lbs UDL each	
ZEUS bins supports 1PLZ and 2 PLZ	
40 ZEUS containers 1PLZ; 44 ZEUS containers 2PLZ; 16 ZEUS containers 3A2PLZ	
3 single slide drawers, with a load capacity of 110.23 lbs, height adjustable, boltless fitting, and a white label holder with clear vinyl protection	
Top, middle and bottom three-point lock	
Concealed hinges to prevent tampering with the door	
Delivered with plastic stabilizers	

Item Code	FAA 1403 56
Dimensions in inches.	40.28" x 21.85" x 78.74" H
Load capacity	1763.7 lbs
It includes a 40.28" x 21.85" x 78.74" h in cabinet	
Swinging metal doors with perforated panels	
4 height adjustable, boltless fitting shelves, 9.84" in depth, 220.46 lbs UDL each	
2 height adjustable, boltless fitting shelves, 19.69" in depth, 220.46 lbs UDL each	
48 ZEUS bin support 1PLZ	
48 ZEUS containers 1PLZ; 5 ZEUS containers 2PLZ; 20 ZEUS containers 3A2PLZ	
3 single slide drawers, with a load capacity of 110.23 lbs, height adjustable, boltless fitting, and a white label holder with clear vinyl protection.	
Top, middle and bottom three-point lock	
Concealed hinges to prevent tampering with the door	
Delivered with plastic stabilizers	

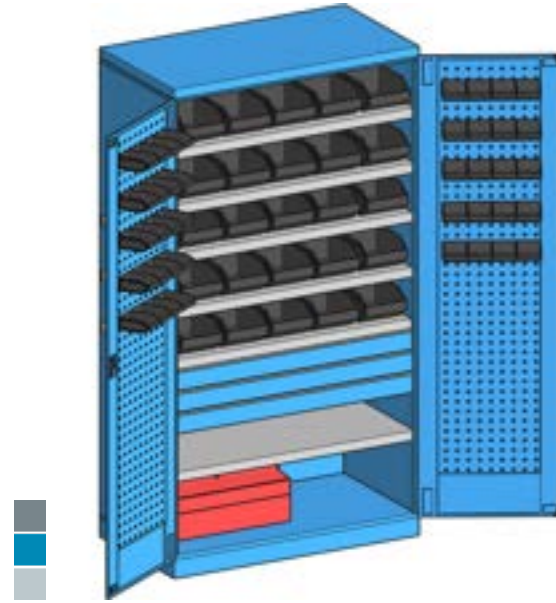

Item Code	FAA 1403 58
Dimensions in inches.	40.28" x 21.85" x 78.74" H
Load capacity	1763.7 lbs
It includes a 40.28" x 21.85" x 78.74" h in cabinet	
Swinging metal doors with perforated panels	
2 perforated panels (38.90" x 0.51" x 17.95" H in)	
4 height adjustable, boltless fitting shelves, 13.58" in depth, 220.46 lbs UDL each	
ZEUS bin support 1PLZ and 2 PLZ	
8 ZEUS containers 1PLZ; 20 ZEUS containers 2PLZ; 8 ZEUS containers 3A2PLZ; 8 ZEUS containers 3PLZ	
Hook Set for 66 tools	
Top, middle and bottom three-point lock	
Concealed hinges to prevent tampering with the door	
Delivered with plastic stabilizers	



Item Code	FAA 1403 60
Dimensions in inches.	40.28" x 21.85" x 78.74" H
Load capacity	1763.7 lbs
It includes a 40.28" x 21.85" x 78.74" h in cabinet	
Swinging metal doors with perforated panels	
2 perforated panels (38.90" x 0.51" x 17.95" H in)	
2 height adjustable, boltless fitting shelves, 19.69" in depth, 220.46 lbs UDL each	
ZEUS bin support 1PLZ and 2 PLZ	
8 ZEUS containers 1PLZ (Dim. 6.30"/5.51" x 3.74" x 2.95" H in) (Capacity 0.26 gal)	
16 ZEUS containers 2PLZ (Dim. 9.06"/7.87" x 5.51" x 5.12" H in) (Capacity 1.00 gal.)	
Hook Set for 66 tools	
Top, middle and bottom three-point lock	
Concealed hinges to prevent tampering with the door	
Delivered with plastic stabilizers	



Item Code	FAA 1403 61
Dimensions in inches.	40.28" x 21.85" x 78.74" H
Load capacity	1763.7 lbs
It includes a 40.28" x 21.85" x 78.74" h in cabinet	
Swinging metal doors with perforated panels	
2 perforated panels (38.90" x 0.51" x 17.95" H in)	
2 height adjustable, boltless fitting shelves, 19.69" in depth, 220.46 lbs UDL each	
8 ZEUS bin supports 1PLZ	
8 ZEUS containers 1PLZ; 16 ZEUS containers 2PLZ	
3 single slide drawers, with a load capacity of 110.23 lbs, height adjustable, boltless fitting, and a white label holder with clear vinyl protection	
Top, middle and bottom three-point lock	
Delivered with plastic stabilizers	

Item Code	FAA 1403 64
Dimensions in inches.	40.28" x 21.85" x 78.74" H
Load capacity	1763.7 lbs
It includes a 40.28" x 21.85" x 78.74" h in cabinet	
Swinging metal doors with perforated panels	
1 height adjustable, boltless fitting shelves, 19.69" in depth, 220.46 lbs UDL each	
3 perforated panels (38.90" x 0.51" x 17.95" H in)	
ZEUS bin support 1PLZ and 2 PLZ	
14 ZEUS containers 1PLZ (Dim. 6.30"/5.51" x 3.74" x 2.95" H in) (Capacity 0.26 gal.)	
28 ZEUS containers 2PLZ (Dim. 9.06"/7.87" x 5.51" x 5.12" H in) (Capacity 1.00 gal.)	
4 single slide drawers, with a load capacity of 110.23 lbs, height adjustable, boltless fitting, and a white label holder with clear vinyl protection	
Hook Set for 66 tools	
Top, middle and bottom three-point lock	
Concealed hinges to prevent tampering with the door	
Delivered with plastic stabilizers	



Item Code	FAA 1403 S2 71
Dimensions in inches.	40.28" x 21.85" x 78.74" H
Load capacity	1763.7 lbs
It includes a 40.28" x 21.85" x 78.74" h in cabinet	
Swinging metal doors with perforated panels.	
1 height adjustable, boltless fitting shelves, 19.69" in depth, 220.46 lbs UDL each	
2 perforated panels (38.90" x 0.51" x 17.95" H in)	
ZEUS Bin support 1PLZ and 2 PLZ	
8 ZEUS containers 1PLZ (Dim. 6.30"/5.51" x 3.74" x 2.95" H in) (Capacity 0.26 gal)	
16 ZEUS containers 2PLZ (Dim. 9.06"/7.87" x 5.51" x 5.12" H in) (Capacity 1.00 gal.)	
9 single slide drawers, with a load capacity of 110.23 lbs, height adjustable, boltless fitting, and a white label holder with clear vinyl protection	
Hook Set for 66 tools	
Top, middle and bottom three-point lock	
Concealed hinges to prevent tampering with the door	
Delivered with plastic stabilizers	



ADJUSTABLE GALVANIZED 15.75" in DEPTH SHELF FOR CABINETS



Item Code	Dimensions in inches	Capacity in lbs
F AC 2350 01 99	39.17" x 13.58" x 1.38" H	220.46

Specially designed for ZEUS Bins 3PLZ and 3A2 PLZ



Model 3PLZ



Model 3A2 PLZ

Full shelves with 4 hooks



ADJUSTABLE GALVANIZED 21.85" in DEPTH SHELF FOR CABINETS



Item Code	Dimensions in inches	Capacity in lbs
F AC 2500 01 99	39.17" x 19.69" x 1.38" H	220.46
F AC 2350 01 99	39.17" x 13.58" x 1.38" H	220.46

Specially designed for ZEUS Bins 4PLZ / 4A5PLZ



Model 4PLZ



Model 4A5 PLZ

Optimize your tool cabinet space by including drawers, panels, shelves and a great variety of accessories that offer flexibility and customization



PERFORATED BACK PANEL

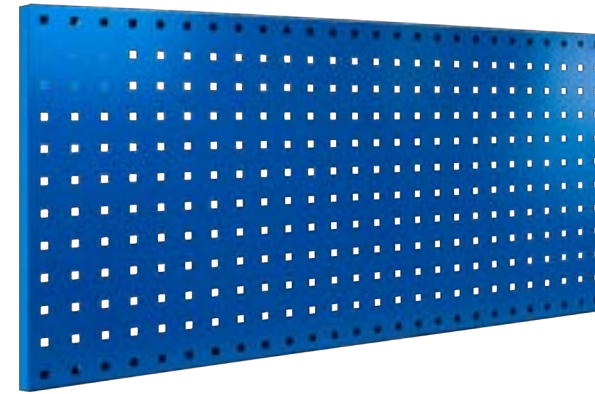

Item Code	Dimensions in inches	Capacity in lbs
F AC 8100 01 04	38.90" x 0.51" x 17.95" H	55.12



21.85" in DEPTH CABINET DRAWERS. LOAD CAPACITY: 110.23lbs, WITH EXCLUSIVE STORAGE COMPAT SLIDES AND BALL BEARINGS

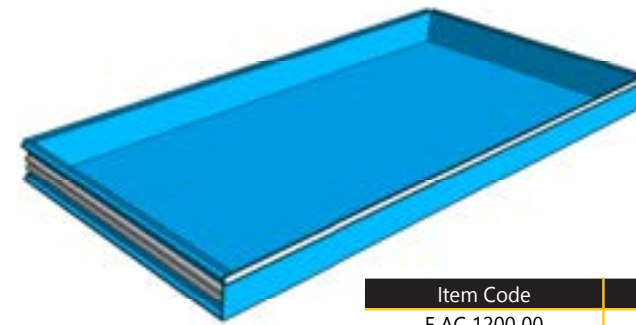

Item Code	Capacity in lbs
F AC 1200 00	110.23



GALVANIZED 1 PLZ SUPPORT



Item	Outer Dim.:	Material
CMV10010	4.21" x 2.80" x 0.04" in.	Galvanized steel sheet

GALVANIZED 2 PLZ SUPPORT



Item	Outer Dim.:	Material
CMV10011	5.94" x 5.04" x 0.04" in.	Galvanized steel sheet



Discover the most effective storage system with **TOOL CABINETS**, the ideal option to keep your materials perfectly organized



JANITORIAL STORAGE CABINETS

Cabinets for personal items. The cabinet structure and doors are secure and very resistant. Their robust level of finish defines them as products with a quality level superior to market standards. Cutting-edge technologies and high-quality materials are used to manufacture them. They are assembled with a folded and welded steel structure -the type of galvanized steel sheet commonly found in the automotive industry, becoming more resistant and with a longer lifespan. After a washing and phosphating treatment, an electrostatic powder coating is applied. Application of the polyurethane paint makes them suitable for outdoor use. They have been specially designed for storage, ensuring perfect conservation and lifespan. They can be used in locker rooms with humidity. They have been certified by the most important paint manufacturers.



JANITORIAL STORAGE CABINETS / WARDROBES



Item Code FAN 1101 01 01

Dimensions in inches. 40.28" x 21.85" x 78.74" H.

Swinging metal doors with magnet

4 Concealed hinges to prevent tampering with the door

Height adjustable shelves (19.69 depth), without bolts and screws.
Shelf load capacity 220.46 lbs.

(It consists of: 1 internal side divider and 3 surfaces FAC 2100
(Dim. 19.02" x 19.69" x 1.38" H inches)

Top, middle and bottom three-point lock

Total load capacity: 1763.70 lbs.



Item Code ESS 1304 01 01

Dimensions in inches. 40.28" x 21.85" x 78.74" H

Metal cabinet

4 swinging metal doors for lockers (Dim. 16.18" x 77.05" H in)

4 Concealed hinges to prevent tampering with the door

8 Internal metal shelves (13.35" x 23.23" x 0.03" H in)

4 Top, middle and bottom three-point lock

2 Keys are included



Item Code FAN 1201 01 01

Dimensions in inches. 23.03" x 19.69" x 68.90" In

Metal cabinet

Swinging door 1 internal side divider

4 Fixed internal shelves - Width: 10.0" in

1 upper shelf - Length: 20.08" in

1 Top, middle and bottom three-point lock



Item Code FAN 5010 01

Dimensions in inches. 23.03" x 15.83" x 68.90" H

Metal cabinet

Clear swinging door with metal frame and magnet

High impact polycarbonate window

Concealed hinges to prevent tampering with the door

1 internal side divider

3 internal shelves

Top, middle and bottom three-point lock



Item Code	FAA 1404 01
Dimensions in inches.	40.28" x 21.85" x 78.74" H
Color	Red RAL3020
Cabinets for fire protection components	
Swinging metal doors with a magnet, and a die-cut acrylic for easy breaking	
4 Height adjustable shelves FAC 2500 00 99 (19.69" in. depth), without bolts or screws.	
Security label kit for the cabinet	
Top, middle and bottom three-point lock	
Total load capacity: 1763.7 lb.	
Concealed hinges to prevent tampering with the door.	

Metal cabinets with swinging doors for correct and approved storing of dangerous substances and fluids, as well as for personal protective equipment (PPE) and fire protection components. The swinging door magnet helps maintain doors closed without using the keys provided. In cabinets for fire protection components, the doors have been manufactured using a partial die-cutting technique, for easy access in case of an emergency, and labels indicating the component functions. These cabinets have been made of galvanized steel sheets commonly found in the automotive industry, and the surfaces have been treated with an electrostatic epoxy powder coating for outdoor use. They are equipped with perforated shelves for the drainage of potential spills, which will be contained by the lower spill -containment tray. Easily adjustable in height with four hooks fitted into the cabinet inside uprights with a 0.98" in. spacing. The combination lock allows its replacement if necessary, and there is a master key for the customer company. They have a 3-point cylinder lock, providing an efficient protection against theft.



Item Code	FAA 1620 01 30
Dimensions in inches.	40.28" x 21.85" x 78.74" H
Color	RAL1004 Amarillo Oro.
Safety storage cabinet with doors and accessories for paints and solvents	
Not intended for stacking	
Compartment usable space: 38.11" (L) x 65.31" in. (h)	
4 height adjustable shelves (19.69 in. depth), without bolts or screws	
Adjustable shelf load: 220.46 lb. UDL	
5.91 in x 5.91 in. Ventilation grille	
Lower spill containment tray. Load capacity: 12.42 gal.	
Load capacity: 1763.7 lb. UDL	
Weight: 209.44 lb.	

Metal shelves with holes

Ventilation grille



(Sliding) Spill containment tray



Ground connection



Height adjustable shelves



High Power Magnet to avoid unintentional door opening



Item Code	FAA 1610 01 30
Dimensions in inches.	40.28 in x 21.85 in x 39.37 in.
Color	RAL1004 Yellow.
Safety storage cabinet with doors and accessories for paints and solvents	
Compartment usable space: 38.11 in (L) x 32.64 in. (H)	
2 height adjustable shelves (19.69 in. depth), without bolts or screws	
Adjustable shelf load: 220.46 lb. UDL	
5.91 in x 5.91 in. Ventilation grille	
Lower spill containment tray. Load capacity: 12.42 gal.	
Load capacity: 1322.77 lb. UDL	
Weight: 108.03 lb.	



Item Code	FAA 1622 01 02
Dimensions in inches.	40.28" x 21.85" x 78.74" H
Color	GREEN RAL 6011
Security cabinet for storing phytosanitary products and pesticides	
Not intended for stacking	
Compartment usable space: 38.11" (L) x 65.31" in. (h)	
4 height adjustable shelves (19.69 in. depth), without bolts or screws	
Adjustable shelf load: 220.46 lb. UDL	
5.91 in x 5.91 in. Ventilation grille	
Lower spill containment tray. Load capacity: 12.42 gal.	
Load capacity: 1322.77 lb. UDL	
Weight: 108.03 lb.	



Item Code	FAA 1612 01 02
Dimensions in inches.	40.28 in x 21.85 in x 39.37 in.
Color	GREEN RAL 6011
Security cabinet for storing phytosanitary products and pesticides	
Compartment usable space: 38.11 in (L) x 32.64 in. (H)	
2 height adjustable shelves (19.69 in. depth), without bolts or screws	
Adjustable shelf load: 220.46 lb. UDL	
5.91 in x 5.91 in. Ventilation grille	
Lower spill containment tray. Load capacity: 12.42 gal.	
Load capacity: 1322.77 lb. UDL	
Weight: 108.03 lb.	

Metal shelves with holes



Three-point lock



Ventilation grille

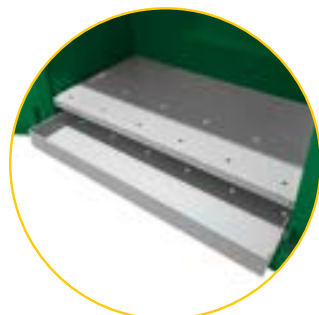

Height adjustable surfaces



High Power Magnet to avoid unintentional door opening

Metal cabinets with swinging doors for correct and approved storing of dangerous substances and fluids (yellow), phytosanitary products (green), as well as for personal protective equipment (PPE).

The swinging door magnet helps maintain doors closed without using the keys provided. As they have been manufactured with galvanized folded steel, commonly found in the automotive industry, cabinets are sturdy and resistant to elements that are naturally aggressive to materials.

Galvanized treatment of laminated steel, together with the washing and phosphating treatment before painting, ensures a surface suitable for receiving a high-standard electrostatic polyurethane powder coating providing the best protection. This means that they can be used, for example, in aggressive and humid environments. The storage of dangerous products, such as inks, solvents (yellow cabinets) or phytosanitary products (green cabinets), ensures environment protection, as they have a spill containment tray.



Computer Cabinets

With computer cabinets, you will be able to use your PC in industrial environments. Computer cabinets can be equipped with plinths for transportation with a forklift or hydraulic pallet truck, as well as wheels for manual transportation from one equipment to another one. Computer cabinets are equipped with a constant filtering system using positive pressure to prevent dust accumulation inside the chassis. An anti-reflective acrylic viewing window provides security for data storage and serves as a standing workstation.

Positive pressure generated inside the cabinet helps eliminate the entry of dust and other environmental contaminants that may damage electronic components, and ventilates the inside with fresh and filtered air. Positive pressure is obtained with a high-efficiency cooler with washable filter media.

Computer cabinets are assembled with a folded and welded steel structure -the type of galvanized steel sheet commonly found in the automotive industry, becoming more resistant and with a longer lifespan. After a washing and phosphating treatment, an electrostatic powder coating is applied. Application of the polyurethane paint makes them suitable for outdoor use. They have been certified by the most important paint manufacturers.

Computer cabinets are efficiently used in, for example, production lines, dispatch areas, resulting in fewer shutdowns due to failures in computer equipment and printers, etc.



COMPUTER CABINET FOR INDUSTRIAL PLANTS

Video access door with a transparent polymer with antireflective coating

Series color:
grey RAL 7000
blue RAL 5012

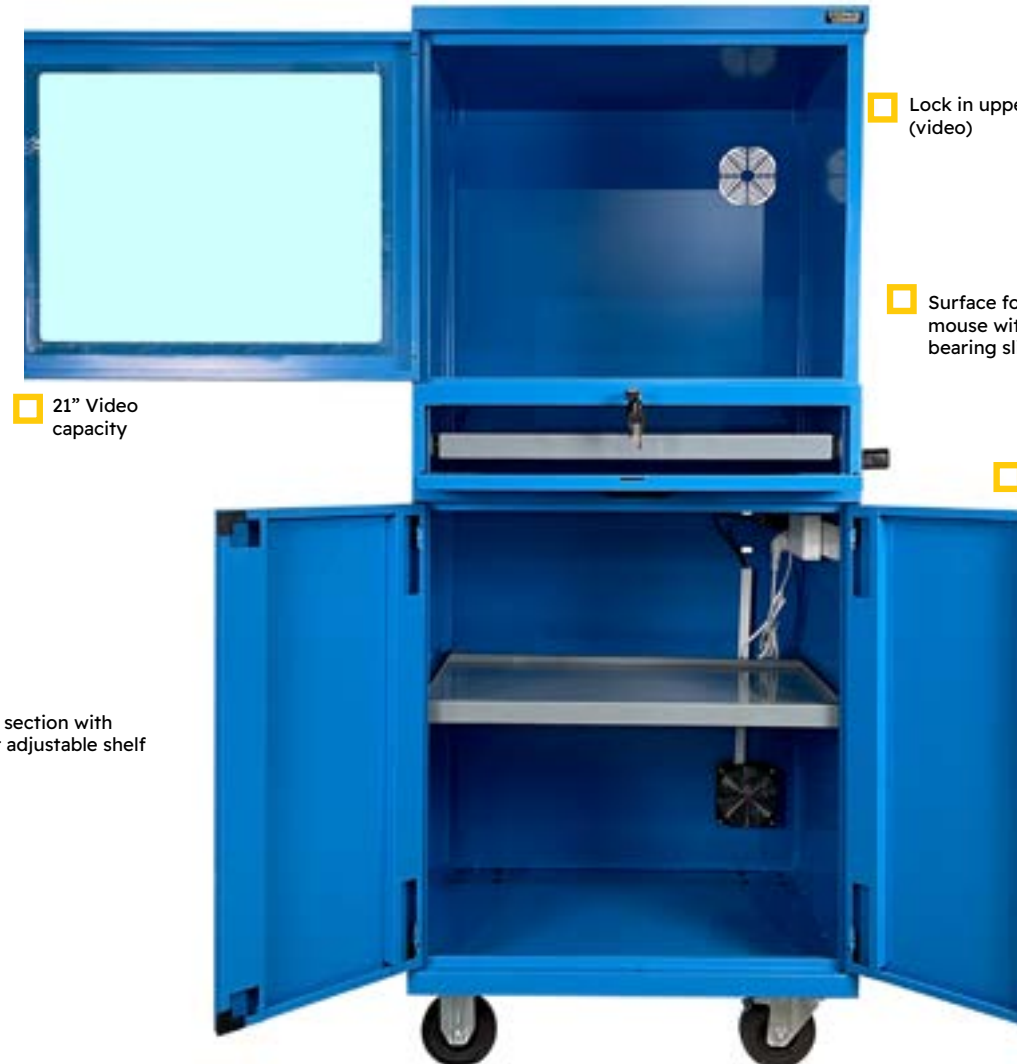

Lock in upper door (video)

Surface for keyboard and mouse with single steel ball-bearing slide

Multiple power strip

21" Video capacity

Lower section with height adjustable shelf

Air filtering system

Manual transportation wheels. 2 rigid and 2 swivel casters with dual-action brakes, in white nylon and pregalvanized forks (optional)

Plinth for handling with a forklift or a hydraulic pallet truck (optional)

Sale on demand with minimum quantities



Item Code	FAS 0801 00
Dimensions in inches.	28.23" x 25.00" x 31.89"
With sliding keyboard tray, locks, electrical installation, and filtered air booster with positive pressure inside the cabinet	



Item Code	FAS 1601 00
Dimensions in inches.	28.23" x 25.00" x 61.42"
With sliding keyboard tray, locks, electrical installation, and filtered air booster with positive pressure inside the cabinet	

In order to avoid the risk of tipping, you must fix the cabinet to the floor using an expansion bolt.



WITH WHEELS

Item Code	FAS 1601 13
Dimensions in inches.	28.23" x 25" x 61.42"
With sliding keyboard tray, locks, electrical installation, and filtered air booster with positive pressure inside the cabinet	

ADJUSTABLE TRAY



Item Code	Load capacity lb..
F AS 2040 01 01	220.46
Dimensions in inches	27.17" x 23.43" x 1.38" H
Useful dim in inches	26.97" x 20.08"

PAIR OF PLINTHS
3.94" in. H



Item Code	Height 3.94" in
F RR 1625 00 07	Front closure
F RR 0645 00 07	

EXTRACTOR



Air Extractor	
Dimensions in inches	4.72" x 4.72" x 1.50"
Full fan with 220 V cable, with grilles and plug	

SLIDING TRAY



Item Code	Load capacity lb..
F AS 2360 00 01	44.09
Dimensions in inches	25.59" x 23.03" x 0.98" H
Useful dim in inches	24.41" x 20.08"

PAIR OF PLINTHS
7.87" in. H

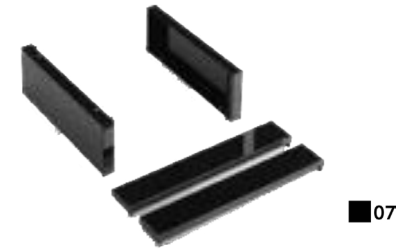

Item Code	Height 7.87" in
F RR 1635 00 07	Front Closure
F RR 0645 00 07	

ELECTRICAL SYSTEM



Multiple Power Strip	
Wall-mounted bipolar power strip. 5 outlets. With a thermal protector switch. Voltage: 250V – Current: 10A	



METAL DRAWER UNITS

Drawers sliding on metal guides with steel ball bearings. Each drawer is designed to support 220.46 lb., and is equipped with a drum lock system including two keys and centralized locking. Each drawer front has a horizontal white label that is protected by a clear vinyl.

This drawer unit is assembled with a folded and welded steel structure -the type of galvanized steel sheet commonly found in the automotive industry, becoming more resistant and with a longer lifespan. They are true mobile warehouses, commonly known as the "assistant" in every day work. Their robustness and load capacity make them unique in our market. After a washing and phosphating treatment, an electrostatic powder coating is applied. Application of the polyurethane paint makes them suitable for outdoor use. They have been certified by the most important paint manufacturers.



Protection rubber



A safety trigger prevents unintentional opening during transportation, avoiding the risk of multiple openings that could lead to tipping, jeopardizing the safety of the operator and the surrounding environment



Inner anti-slip rubber and comb dividers



Wheels are mounted on hub and thrust bearings with a dual-action break system that ensures stability when stopping to work

Item Code	FDD 1030 52
Dimensions in inches.	22.20" x 28.58" x 15.08" H.
1 single slide metal drawer 1.97 in. H (17.60" x 23.62" x 1.42") (87% sliding capacity) Mounted on steel ball bearings, 220.46 lb. UDL	
1 single slide metal drawer 3.94 in. H (17.60" x 23.62" x 3.39") (87% sliding capacity) Mounted on steel ball bearings, 220.46 lb. UDL	
1 single slide metal drawer 5.91 in. H (17.60" x 23.62" x 5.35") (87% sliding capacity) Mounted on steel ball bearings, 220.46 lb. UDL	
Drum lock with two keys and centralized locking	



Item Code	FDD 1070 55
Dimensions in inches.	22.20" x 28.58" x 31.50" H
2 single slide metal drawer 3.94 in. H (17.60" x 23.62" x 3.39") (87% sliding capacity) Mounted on steel ball bearings, 220.46 lb. UDL	
1 single slide metal drawer 7.87 in. H (17.60" x 23.62" x 7.32") (87% sliding capacity) Mounted on steel ball bearings, 220.46 lb. UDL	
1 single slide metal drawer 11.81 in. H (17.60" x 23.62" x 11.26") (87% sliding capacity) Mounted on steel ball bearings, 220.46 lb. UDL	
Drum lock with two keys and centralized locking	



Item Code	FDD E070 56
Dimensions in inches.	22.20" x 28.58" x 39.37" H
2 swivel casters with brake Ø 4.92 in. made of standard rubber	
2 rigid casters Ø 4.92 in. made of standard rubber	
2 single slide metal drawer 3.94 in. H (17.60" x 23.62" x 3.39") (87% sliding capacity) Mounted on steel ball bearings, 220.46 lb. UDL	
1 single slide metal drawer 7.87 in. H (17.60" x 23.62" x 7.32") (87% sliding capacity) Mounted on steel ball bearings, 220.46 lb. UDL	
1 single slide metal drawer 11.81 in. H (17.60" x 23.62" x 11.26") (87% sliding capacity) Mounted on steel ball bearings, 220.46 lb. UDL	
Top tray with perimeter edge	
Drum lock with two keys and centralized locking	



Item Code	F BG 3030 01
Dimensions in inches.	19.69" x 23.90" x 22.44" H.
3 telescopic slide metal drawer 13.98" x 19.88" x 6.10" H	
Load capacity per drawer: 66.14 lb.	
Simple side latch lock	
Drum lock with two keys and centralized locking	

DRAWER AND DRAWER UNIT



Metal frame



Telescopic slides

 DRAWER UNITS and DRAWER CARTS can be assembled in line with your needs. Drawer sizes available: 50 / 100 / 150 / 200 / 300



MODULAR SHELVING UNITS WITH BINS

Profiled steel sheet shelving modules and configurable metal guides with ZEUS plastic bins. They are very resistant, even when fully loaded. They are assembled with a folded and welded steel structure -the type of galvanized steel sheet commonly found in the automotive industry, becoming more resistant and with a longer lifespan.

The stackable shelving units and their modular features offer an excellent stacking stability, allowing the creation of high-bay warehouses or low counters that may be modified according to each customer's needs. This system helps organize customized warehouses. Labels, which are provided separately, can be attached to plastic bins, saving storage and picking times. The maximum stack height is 3 modules. Plastic bins may be provided with labels in order to ensure a rapid and effective classification.



As modular shelving units are stackable, you can create high-bay warehouses or low counters which, in combination with the ladder cart, allow a rapid warehouse management with a large number of references.



Item Code	FED 3044 00 01
Outer dim. in inches	40.35" x 12.20" x 34.84" H
Stackable module for 16 bin units Model 3PLZ (Dim. 13.78"/11.81" x 7.87" x 7.87" H Capacity 3.30 gal.)	
Load capacity: 1410.96 lb. in each frame	
Load capacity per bin: 88.18 lb.	



Code	Dimensions in inches.
FED 3044 00	40.35" x 12.20" x 34.84" H
Shelves without bins	
Approximate shelving unit weight: 57.32 lb.	



Item Code	FED 3074 00 01
Outer dim. in inches	69.49" x 12.20" x 34.84" H
Stackable module for 28 bin units Model 3PLZ (Dim. 13.78"/11.81" x 7.87" x 7.87" H Capacity 3.30 gal.)	
Load capacity: 2469.16 lb. in each frame	
Load capacity per bin: 88.18 lb.	

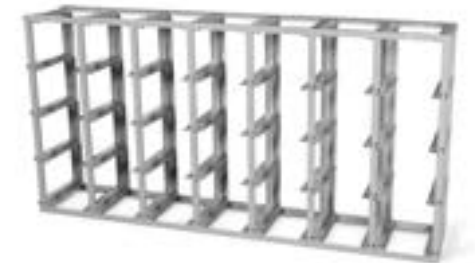

Item Code	Dimensions in inches.
FED 3074 00	69.49" x 12.20" x 34.84" H
Shelves without bins	
Approximate shelving unit weight: 94.8 lb.	



Item Code	FED 4054 00 01
Outer dim. in inches	69.49" x 18.11" x 34.84" H
Módulo apilable para 20 unidades de contenedor Med. 4PLZ (Dim. 19.69"/17.72" x 11.81" x 7.87" H. Capacity. 7.40 gal.)	
Load capacity: 3527.4 lb. en cada bastidor.	
Load capacity por contenedor: 176.37 lb.	



Code	Dimensions in inches.
FED 4054 00	69.49" x 18.11" x 34.84" H
Shelves without bins	
Approximate shelving unit weight: 104.72 lb.	



Item Code	FED 4034 00 01
Outer dim. in inches	42.32" x 18.11" x 34.84" H
Stackable module for 12 bin units Model 4PLZ (Dim. 19.69"/17.72" x 11.81" x 7.87" H. Capacity. 7.40 gal.)	
Load capacity: 2645.55 lb. in each frame	
Load capacity per bin: 220.46 lb.	



Item Code	Dimensions in inches.
FED 4034 00	42.32" x 18.11" x 34.84" H
Shelves without bins	
Approximate shelving unit weight: 66.14 lb.	



Item Code	FED 4056 00 01
Outer dim. in inches	69.49" x 18.11" x 51.18"H
Stackable module for 30 bin units Model 4PLZ (Dim. 19.69"/17.72" x 11.81" x 7.87" H. Capacity. 7.40 gal.)	
Load capacity: 5291.71 lb. in each frame.	
Load capacity per bin: 110.23 lb.	

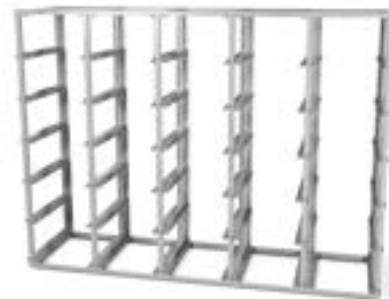

Item Code	Dimensions in inches.
FED 4056 00	69.49" x 18.11" x 51.18"H
Shelves without bins	
Approximate shelving unit weight: 147.71 lb.	



Item Code	FED 4555 00 01
Outer dim. in inches	69.49" x 18.11" x 51.18"H
ZEUS Series Plastic bins 4A5PLZ with crossbar (Dim. 19.69/17.72" x 11.81" x 11.81" H Capacity 11.10 gal.)	
Load capacity: 2645.55 lb. in each frame	
Load capacity per bin: 110.23 lb.	

Item Code	Dimensions in inches.
FED 4055 00	69.49" x 18.11" x 51.18"H
Shelves without bins	
Approximate shelving unit weight: 125.66 lb.	

Ask for information about bin dividers



Item Code	Outer dim. in inches	Shelving Unit Item
FED 9234 00 01	40.16" x 12.40" x 3.35" H	FED 3044 00
FED 9243 00 01	42.13" x 18.31" x 3.35" H	FED 4034 00
FED 9237 00 01	69.49" x 12.40" x 3.35" H	FED 3074 00
FED 9245 00 01	69.49" x 18.31" x 3.35" H	FED 4054 00
		FED 4056 00
		FED 4055 00

Module base



Item Code	Outer dim. in inches	Shelving Unit Item
FED 9045 00 01	69.49" x 18.31" x 0.79"	FED 4055 00
		FED 4056 00
		FED 4054 00
FED 9043 00 01	42.13" x 18.31" x 0.79"	FED 4034 00
FED 9037 00 01	69.49" x 12.40" x 0.79"	FED 3074 00
FED 9034 00 01	40.16" x 12.40" x 0.79"	FED 3044 00

Dust cover





Load capacity per module: 5070.93 lb.

This shelving system has been designed to reduce implementation and facilities relocation costs. In a modern, versatile and always dynamic industry, relocation changes are very common, and equipment investment must include the possibility of moving all equipment rapidly and efficiently, without affecting operations while protecting the investment.

Our 100% fitting system needs no screws or expensive operations to be assembled or disassembled. It allows optimization of hidden costs, maintenance of a modern image and efficient storage of ZEUS and ATHENA plastic bins or containers, as well as other standardized storage devices. With different enclosure options, doors or mezzanine floors, these shelving units are really storage units that can be adjusted and adapted to every need.

Space-saving, time-efficiency, and safety are the core principles of our equipment.

Our shelving units are assembled with a folded and welded steel structure -the type of galvanized steel sheet commonly found in the automotive industry, becoming more resistant and with a longer lifespan. After a washing and phosphating treatment, an electrostatic powder coating is applied. Application of the polyurethane paint makes them suitable for outdoor use. They have been certified by the most important paint manufacturers, ensuring their quality and durability.



Load capacity in each shelf: from 176.37 lb. to 771.62 lb.

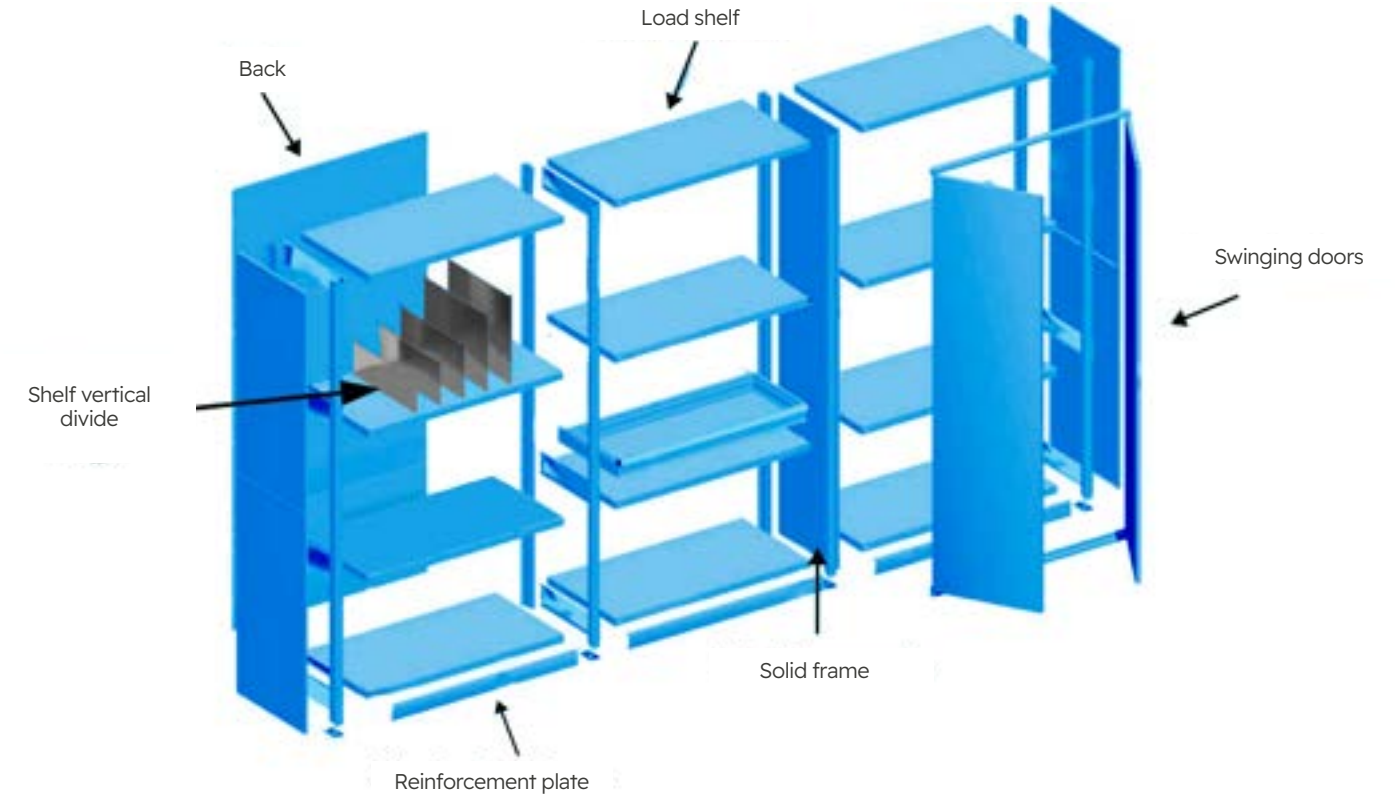

Open upright posts or frames

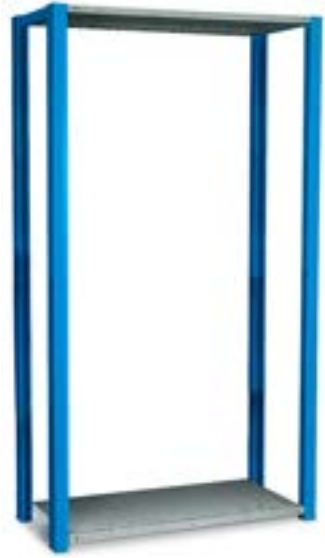

Upright height in inches	Upright crossbars	Intermediate upright crossbars	Upright Type		
			15.75 in.	19.69 in.	23.62 in.
39.76"	2	**	9152	9154	9156
59.45"	2	**	9160	9162	9164
79.13"	2	**	9169	9171	9173
98.82"	2	1	9176	9178	9180
118.50"	2	2	9184	9186	9188

Solid upright posts or frames

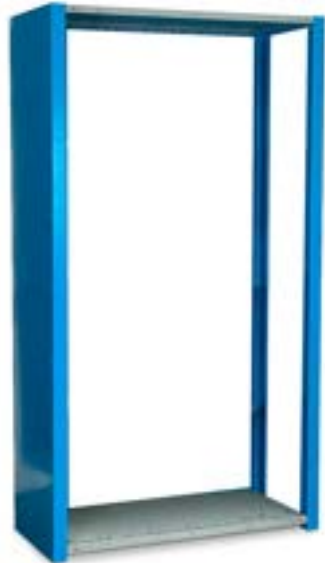

Upright height in inches.	Upright crossbars	Upright Type		
		15.75 in.	19.69 in.	23.62 in.
39.76"	2	9152 CL	9154 CL	9156 CL
59.45"	2	9160 CL	9162 CL	9164 CL
79.13"	2	9169 CL	9171 CL	9173 CL
98.82"	2	9176 CL	9178 CL	9180 CL
118.50"	2	9184 CL	9186 CL	9188 CL

Shelves or load surfaces:



4 fitting hooks are included with each shelf

MODEL	Dim in inches	Number of lower reinforcements	Load capacity in lb.
8014	39.37" x 15.75"	**	176.37
8016	39.37" x 15.75"	1	440.92
8018	39.37" x 19.69"	**	176.37
8020	39.37" x 19.69"	1	440.92
8022	39.37" x 19.69"	2	551.16
8024	39.37" x 23.62"	1	440.92
8026	39.37" x 23.62"	2	551.16



Item Code 9076
Rear reinforcement plate (1 every 3 modules)



Item Code 9074
Additional hook



Item Code 9100
Rear reinforcement plate (1 every 3 modules)

Upright height in inches	Number of backs
40.94"	2
59.06"	3
79.13"	4
97.24"	5
117.32"	6



Item Code 9114
71.6" Inches door pair



Item Code 9110
33.46" H inches door pair



Implementation



Item Code	9129 Medida: 14.06" x 12.24"
Item Code	9130 Medida: 14.06" x 14.25"
Item Code	9135 Medida: 17.99" x 12.24"
Item Code	9136 Medida: 17.99" x 14.25"
Item Code	9141 Medida: 21.93" x 12.24"
Item Code	9142 Medida: 21.93" x 14.25"

UNINORM metal shelving units combine the best of a shelving unit with technology and an exclusive tool storage cabinet. They offer logistic modular solutions that are innovative, high performing, safe and customized, with unique options in the industrial furniture market. Their perfect combination of a cabinet and a metal shelving unit makes it possible to obtain a robust, versatile and modular system for storing goods.



ADJUSTABLE SHELVES, BOLTLESS SHELVES AND SHELF ENCLOSURES

Intermediate height-adjustable shelves are supported by 4 hooks. They have slots to add dividers with a load capacity of more than 220.46 lb. UDL.

Shelf enclosures, which have the same support function as boltless shelves, are designed to hold the drum lock or the combination lock, and support the perforated strut. They also have a 330.69 lb. load capacity.



SIDE, CENTRAL AND REAR WALLS

Side, central, and rear walls are made of steel sheets that are united together to form enclosed compartments.



SIDES

Made of steel. Components, including uprights, connecting bars, and feet, are welded together, increasing the load capacity per shelf and module.

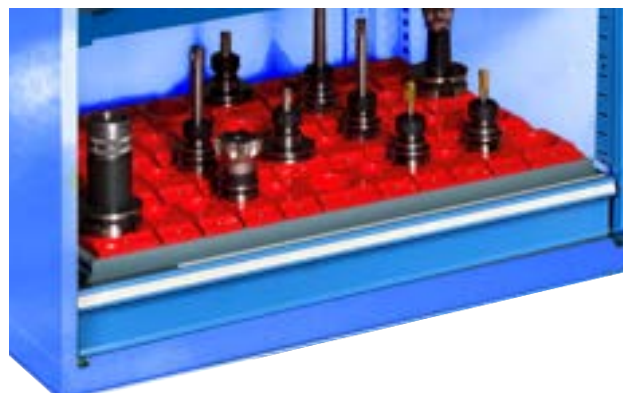

DRAWERS WITH TELESCOPIC SLIDES



CYLINDRICAL LOCK

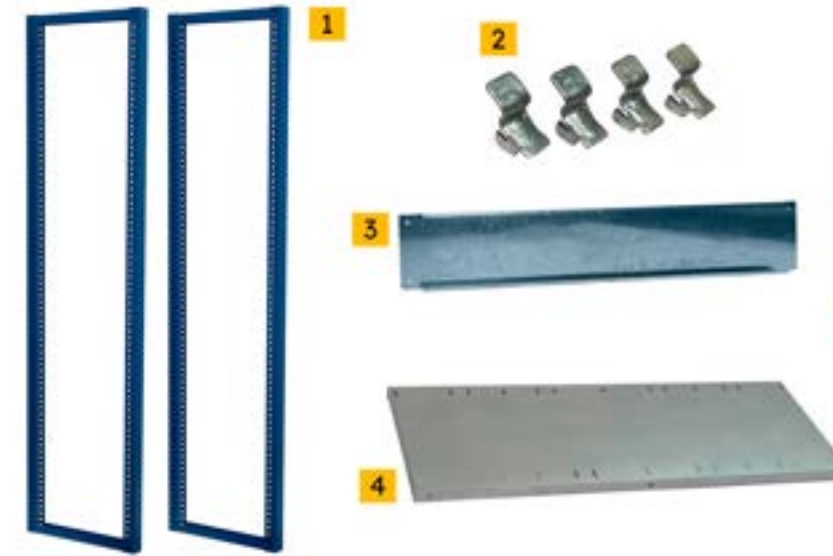

- 1- Frames
- 2 - Fitting hooks
- 3 - Reinforcement plate
- 4 - Shelves



With an innovative, boltless fitting shelving unit design, the Uninorm system stands out as the most modern and efficient option in the storage market.

Its rapid installation and versatility make it an ideal solution for a great variety of projects, from industrial and commercial environments to logistic and domestic applications.

Its ability to maximize the useful space through a rapid and effortless shelf adjustment, without using any bolts, makes the Uninorm system a leader in space saving and storage optimization.

Besides, its simple assembly and disassembly features help save in installation costs and movement, ensuring long-term durability and efficacy.

With features ranging from door security and locks to its ability to handle heavy loads, and efficient sorting with modular plastic containers, the Uninorm system provides a comprehensive solution for all storage needs.

It may be customized, with sliding trays and interior dividers, so users are free to adapt the storage space to their specific needs, optimizing their inventory management experience and cutting down on stock costs and implementation times.

In summary, the Uninorm system represents a comprehensive and effective solution for intelligent storage management, offering a perfect balance between functionality, efficiency, and versatility in any work environment.

MOBILE SAFETY LADDER



Item Code FCR 0300 00 01
Load capacity: 330.69 lb.



1 Pressing the first step



2 the ladder cart descends on four legs fixed to the floor for safety reasons.



3 If the lever is stepped on, the ladder rises and locks onto 4 wheels.



IT'S READY NOW TO BE MOVED!

STORAGE COMPAT®



STORAGE COMPAT

Blue Lagoon, Miami Nth, Florida.
sales@storagecompat.com
+1 (954) 756-2992